



HY13-1526-004-M1/US

Torqmotor™ Service Procedure

Effective: **January 2025**



TC, TS, TB, TE and TJ
Series

Low Speed, High Torque
Hydraulic Torqmotors™



WARNING

FAILURE OR IMPROPER SELECTION OR IMPROPER USE OF THE PRODUCTS AND/OR SYSTEMS DESCRIBED HEREIN OR RELATED ITEMS CAN CAUSE DEATH, PERSONAL INJURY AND PROPERTY DAMAGE.

This document and other information from Parker Hannifin Corporation, its subsidiaries and authorized distributors provide product and/or system options for further investigation by users having technical expertise. It is important that you analyze all aspects of your application and review the information concerning the product or system in the current product catalog. Due to the variety of operating conditions and applications for these products or systems, the user, through its own analysis and testing, is solely responsible for making the final selection of the products and systems and assuring that all performance, safety and warning requirements of the application are met.

The products described herein, including without limitation, product features, specifications, designs, availability and pricing, are subject to change by Parker Hannifin Corporation and its subsidiaries at any time without notice.

Offer of Sale

The items described in this document are hereby offered for sale by Parker Hannifin Corporation, its subsidiaries or its authorized distributors. This offer and its acceptance are governed by the provisions stated in the "Offer of Sale".

© Copyright 2017, 2015, 2007 - 2005, 2000, 1999, Parker Hannifin Corporation, All Rights Reserved

Definitions.....	3
Design Features	4 - 5
Introduction	6
Troubleshooting Guide	7
Troubleshooting Checklist.....	8
Tools and Material Required for Servicing.....	9
Bolt Torque	10
Exploded Assembly View	11-17
TC Service Parts List Chart	18-19
TS Service Parts List Chart	20
TB Service Parts List Chart	21-22
TE Service Parts List Chart	23-24
TJ Service Parts List Chart.....	25-26
Disassembly & Inspection	27-35
Torqmotor™ Assembly.....	36-46
Rotor Set Component Assembly Procedure (One Piece Stator).....	47
Rotor Set Component Assembly Procedure (Two Piece Stator).....	48-49
Final Checks.....	50
Hydraulic Fluids, Filtration, Oil Temperature	50
Tips for Maintaining the System.....	51
Offer of Sale	Inside Back Cover

Definitions

- NOTE:** A NOTE provides key information to make a procedure easier or quicker to complete.
- CAUTION:** A CAUTION refers to procedure that must be followed to avoid damaging the Torqmotor™ or other system components.
- WARNING:** A WARNING REFERS TO PROCEDURE THAT MUST BE FOLLOWED FOR THE SAFETY OF THE EQUIPMENT OPERATOR AND THE PERSON INSPECTING OR REPAIRING THE TORQMOTOR™.

Disclaimer

This Service Manual has been prepared by Parker Hannifin for reference and use by mechanics who have been trained to repair and service hydraulic motors and systems on commercial and non-commercial equipment applications. Parker Hannifin has exercised reasonable care and diligence to present accurate, clear and complete information and instructions regarding the techniques and tools required for maintaining, repairing and servicing the complete line of Parker TC, TS, TB, TE and TJ Torqmotor™ Units. However, despite the care and effort taken in preparing this general Service Manual, Parker **makes no warranties** that (a) the Service Manual or any explanations, illustrations, information, techniques or tools described herein are either accurate, complete or correct as applied to a specific Torqmotor™ unit, or (b) any repairs or service of a particular Torqmotor™ unit will result in a properly functioning Torqmotor™ unit.

If inspection or testing reveals evidence of abnormal wear or damage to the Torqmotor™ unit or if you encounter circumstances not covered in the Manual, STOP – CONSULT THE EQUIPMENT MANUFACTURER’S SERVICE MANUAL AND WARRANTY. DO NOT TRY TO REPAIR OR SERVICE A TORQMOTOR™ UNIT WHICH HAS BEEN DAMAGED OR INCLUDES ANY PART THAT SHOWS EXCESSIVE WEAR UNLESS THE DAMAGED AND WORN PARTS ARE REPLACED WITH ORIGINAL PARKER REPLACEMENT AND SERVICE PARTS AND THE UNIT IS RESTORED TO PARKER SPECIFICATIONS FOR THE TORQMOTOR™ UNIT.

It is the responsibility of the mechanic performing the maintenance, repairs or service on a particular Torqmotor™ unit to (a) inspect the unit for abnormal wear and damage, (b) choose a repair procedure which will not endanger his/her safety, the safety of others, the equipment, or the safe operation of the Torqmotor™, and (c) fully inspect and test the Torqmotor™ unit and the hydraulic system to insure that the repair or service of the Torqmotor™ unit has been properly performed and that the Torqmotor™ and hydraulic system will function properly.

Torqmotor™ Design Features

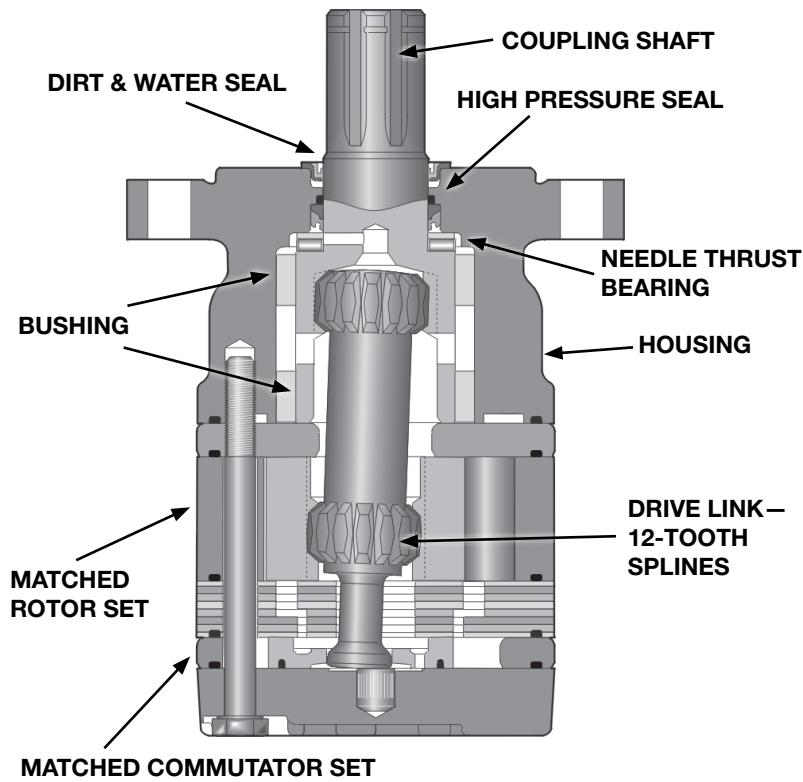

Torqmotor™ TB/TC Series features include:

- The roller vane rotor set design offers a low-friction, wear compensation which maximizes the useful performance life of the motor.
- Zero leak **commutation valve provides greater, more consistent volumetric efficiency.**
- Design flexibility - TB offers the widest selection of shaft options, displacements and mounting flanges in the industry.
- Patented 60-40 spline member arrangement transmits more torque with less weight.
- Full flow lubrication maximizes cooling and may provide up to 50% longer life than motors not having this feature.
- Higher pressure rating provide greater torque than competitive brands.
- Full interchangeability with other motors which are designed according to industry standards.
- Compatible with most hydraulic systems with regard to pressure, torque and speed.
- A unique high-pressure shaft seal that eliminates the need for case drains.
- Up to 18 horsepower output.

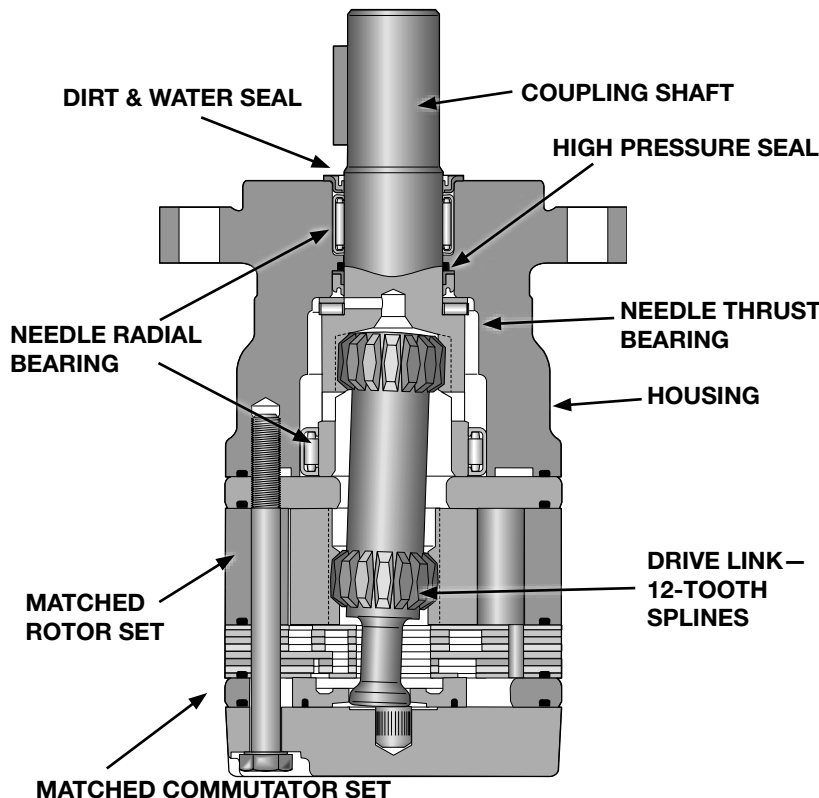

Torqmotor™ TE Series features include:

- Roller vanes to reduce friction and internal leakage and to maintain efficiency.
- Zero leak **commutation valve provides greater, more consistent volumetric efficiency.**
- Wheel mount version available.
- More starting torque than competitive motors in applications where the shaft is side loaded. (Competitive brands require more pressure to start the motor.)
- A needle-roller mounted coupling shaft and steel-caged thrust bearing which can withstand 1000-pound thrust loads.
- Side load capacity is 1600 lbs. (727.3 kg) maximum at center of output shaft.
- A unique high-pressure shaft seal that eliminates the need for case drains, check valves and extra plumbing.
- Up to 23 horsepower output.
- Greater durability due to superior lubrication and minimum drive spline wear.
- Patented 60-40 spline member arrangement transmits more torque with less weight.

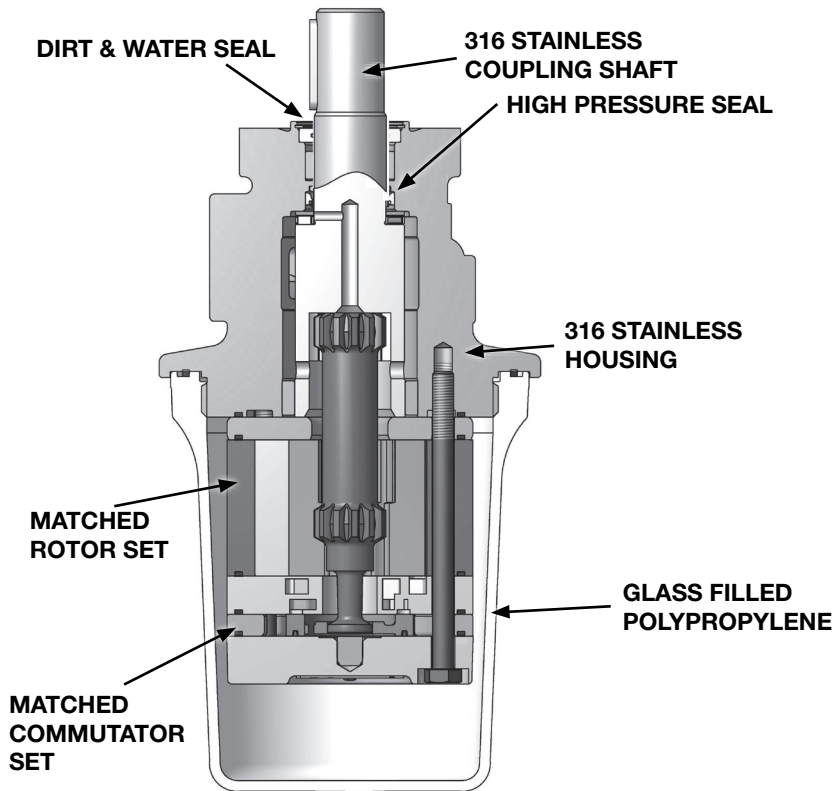

Torqmotor™ TS Series features include:

- The roller vane rotor set design offers a low-friction, wear compensation which maximizes the useful performance life of the motor.
- Zero leak commutation valve provides greater, more consistent volumetric efficiency.
- Design flexibility—TS offers the 316 stainless steel housing and shaft with a one-size-fits-all displacements polypropylene cover.
- Patented 60-40 spline member arrangement transmits more torque with less weight.
- Full flow lubrication maximizes cooling and may provide up to 50% longer life than motors not having this feature.
- Higher pressure rating provides greater torque than competitive brands.
- Full interchangeability with other motors which are designed according to industry standards.
- Compatible with most hydraulic systems with regard to pressure, torque and speed.
- A unique high-pressure shaft seal that eliminates the need for case drains.
- Up to 13 horsepower output.

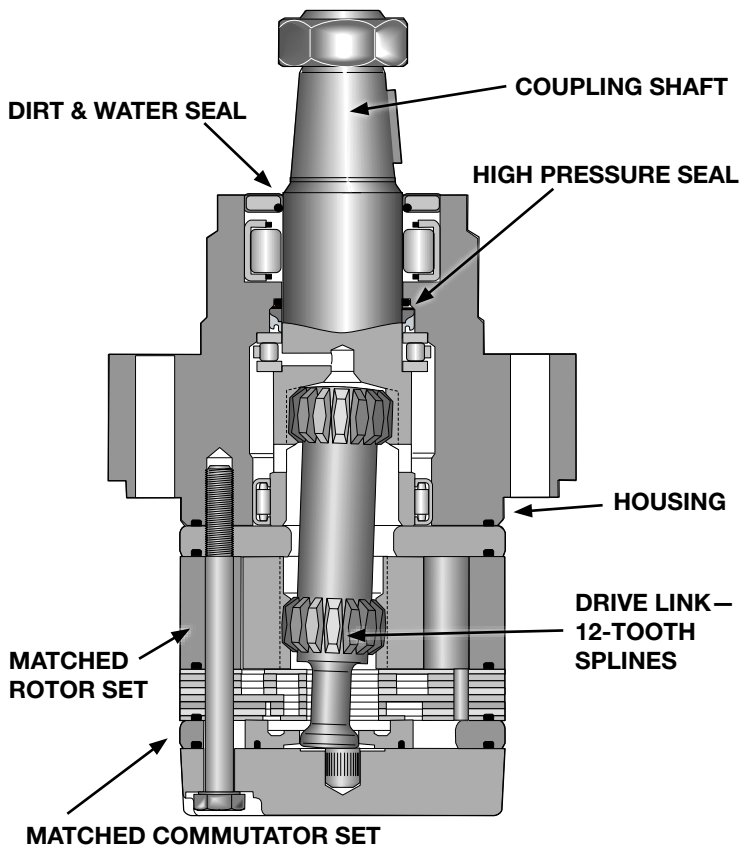

Torqmotor™ TJ Series features include:

- The roller vane rotor set design offers a low-friction, wear compensation which maximizes the useful performance life of the motor.
- Zero leak commutation valve provides greater, more consistent volumetric efficiency.
- Patented 60-40 spline member arrangement transmits more torque with less weight.
- Full flow lubrication maximizes cooling and may provide up to 50% longer life than motors not having this feature.
- Higher pressure rating provides greater torque than competitive brands.
- Full interchangeability with other motors which are designed according to industry standards.
- Compatible with most hydraulic systems with regard to pressure, torque and speed.
- A unique high-pressure shaft seal that eliminates the need for case drains.
- Up to 23 horsepower output.

Introduction

This service manual has one purpose: to guide you in maintaining, troubleshooting, and servicing the TC, TS, TB, TE and TJ Torqmotor™ (low-speed, high-torque hydraulic motor).

Material in this manual is organized so you can work on the Torqmotor™ and get results without wasting time or being confused. To get these results, you should read this entire manual before you begin any work on the Torqmotor™.

This manual also contains troubleshooting information and checklist. If you must service the Torqmotor™, the checklist will help you to determine where the problem may be.

The three-column format of the Disassembly and Inspection, and Assembly sections will make it easier for you to conduct major work on the Torqmotor™. Column 1 gives a brief key for each procedure. Column 2 explains in detail the procedure you should follow. Column 3 illustrates this procedure with photographs. Read all material carefully and pay special attention to the notes, cautions, and warnings.

A page with the Torqmotor™ exploded assembly view is provided several places in this manual. The component part names and item numbers assigned on this exploded assembly view correspond with names and item numbers (in parentheses) used in the disassembly and assembly procedures set forth in this manual. Service part list charts are also provided in this manual with the part names and exploded view item numbers cross referenced to Parker service part numbers.

Service parts are available through the Original Equipment Manufacturer or Parker approved TC, TS, TB, TE and TJ Distributors.

As you gain experience in servicing the Torqmotor™, you may find that some information in this manual could be clearer or more complete. If so, let us know about it. Do not try to second guess the manual. If you are stuck, contact us. Servicing the Torqmotor™ should be a safe and productive procedure, in order for the unit to deliver the reliable, long-life operation engineered into it.

Troubleshooting Guide

NOTE: Before troubleshooting any system problem, check service literature published by the equipment and/or component manufacturers. Follow their instructions, if given, for checking any component other than the Torqmotor™ unit.

Preparation

Make your troubleshooting easier by preparing as follows:

- work in a clean, well-lighted place;
- have proper tools and materials nearby;
- have an adequate supply of clean petroleum-base-solvent.

WARNING: SINCE SOLVENTS ARE FLAMMABLE, BE EXTREMELY CAREFUL WHEN USING ANY SOLVENT, EVEN A SMALL EXPLOSION OR FIRE COULD CAUSE INJURY OR DEATH.

WARNING: WEAR EYE PROTECTION AND BE SURE TO COMPLY WITH OSHA AND OTHER MAXIMUM AIR PRESSURE REQUIREMENTS.

Preliminary Checks

Hydraulic systems are often trouble-free. Hence, the problem an operator complains of could be caused by something other than the hydraulic components.

Thus, once you have determined that a problem exists, start with the easy-to-check items, such as:

- parts damaged from impact that were not properly repaired, or that should have been replaced; and
- improper replacement parts used in previous servicing
- mechanical linkage problems such as binding, broken, or loose parts or slipping belts

Hydraulic Components

If you think the problem is caused by a hydraulic component, start by checking the easy-to-reach items.

Check all hoses and lines for cracks, hardening, or other signs of wear. Reroute any usable hoses that are kinked, severely bent, or that rest against hot engine parts. Look for leaks, especially at couplings and fittings. Replace any hoses or lines that don't meet system flow and pressure ratings.

Next, go to the reservoir and filter or filters. Check fluid level and look for air bubbles. Check the filter(s). A filter with a maximum 40 micron filtration is recommended for the Torqmotor™ system.

Visually check other components to see if they are loosely mounted, show signs of leaks, or other damage or wear.

Excessive heat in a hydraulic system can create problems that can easily be overlooked. Every system has its limitation for the maximum amount of temperature. After the temperature is attained and passed, the following can occur:

- oil seal leaks
- loss of efficiency such as speed and torque
- pump loss of efficiency
- pump failure
- hoses become hard and brittle
- hose failure

A normal temperature range means an efficient hydraulic system. Consult the manuals published by equipment and/or component manufacturers for maximum allowable temperature and hydraulic tests that may be necessary to run on the performance of the hydraulic components. The Torqmotor™ is not recommended for hydraulic systems with maximum temperatures above 200°F (93.3°C).

Troubleshooting Checklist

Trouble	Cause	Remedy
Oil Leakage	1. Hose fittings loose, worn or damaged.	Check & replace damaged fittings or “O” Rings. Torque to manufacturers specifications.
	2. Oil seal rings (3) deteriorated by excess heat.	Replace oil seal rings by disassembling Torqmotor™ unit.
	3. Special bolt (1, 1A, 1B or 1C) loose or its sealing area deteriorated by corrosion.	(a) Loosen then tighten single bolt to torque specification. (b) Replace bolt.
	4. Internal shaft seal (14) worn or damaged.	Replace seal. Disassembly of Torqmotor™ unit necessary.
	5. Worn coupling shaft (10) and internal seal (14).	Replace coupling shaft and seal by disassembling Torqmotor™ unit.
Significant loss of speed under load	1. Lack of sufficient oil supply	(a) Check for faulty relief valve and adjust or replace as required. (b) Check for and repair worn pump. (c) Check for and use correct oil for temperature of operation.
	2. High internal motor leakage	Replace worn rotor set by disassembling Torqmotor™ unit.
	3. Severely worn or damaged internal splines.	Replace rotor set, drive link and coupling shaft by disassembling Torqmotor™ unit.
	4. Excessive heat.	Locate excessive heat source (usually a restriction) in the system and correct the condition.
Low mechanical efficiency or undue high pressure required to operate Torqmotor™ unit	1. Line blockage	Locate blockage source and repair or replace.
	2. Internal interference	Disassemble Torqmotor™ unit, identify and remedy cause and repair, replacing parts as necessary.
	3. Lack of pumping pressure	Check for and repair worn pump.
	4. Excessive binding or loading in system external to Torqmotor™ unit.	Locate source and eliminate cause.

CAUTION: If the hydraulic system fluid becomes overheated [in excess of 200°F (93.3°C)], seals in the system can shrink, harden or crack, thus losing their sealing ability.

Tools and Materials Required for Servicing

- Clean, petroleum-based solvent
- Emery paper
- Vise with soft jaws
- Air pressure source
- Arbor press
- Screw driver
- Masking tape
- Breaker bar
- Torque wrench-ft. lbs. (N m)
- Sockets: 1/2 or 9/16 inch thin wall, 1 inch
- Allen Sockets: 3/16, 3/8 inch
- Adjustable crescent wrench or hose fitting wrenches
- SAE 10W40 SE or SF oil
- Special bearing mandrel for TC, TS, TB & TE Torqmotors (SEE FIGURE 1)
- Feeler gage .005 inch (.13 mm)
- TC, TS, TB & TE Torqmotors require blind hole bearing puller for 1.06 inch (26.9) mm) and 1.62 inch (41.1 mm) diameter bearing/bushing.
- TJ requires blind hole bearing puller for 1.400 inch diameter (35.6 mm) and 2.130 inch diameter (5.41 mm) bearing
- Clean corrosion resistant grease. Part #406018 is included in each seal kit. Recommended grease is Parker Specification #045236 or Mobil Mobilith SHC® 460

NOTE: The available service seal kits include the recommended grease as a grease pack #406018

CAUTION: Mixing greases that have different bases can be detrimental to bearing life.

Technical Information

CONVERSIONS

INCHES	mm	INCHES	mm
.020	.51	1.060	26.92
.021	.53	1.295	32.89
.029	.74	1.297	32.94
.030	.76	1.396	35.46
.111	2.81	1.398	35.51
.119	3.02	1.620	41.15
.152	3.86	1.622	41.20
.160	4.06	1.983	50.37
.296	7.52	1.985	50.42
.304	7.72	2.120	53.85
.460	11.68	2.122	53.90
.470	11.94	2.233	56.72
.500	12.70	2.235	56.77
.585	14.86	2.483	63.07
.595	15.11	2.485	63.12
.660	16.76	2.500	63.5
.675	17.15	2.88	73.2
1.058	26.87		

Torque Chart

Part Name	Item Number	Torque
bolt 5/16 24 UNF 2A	1, 1A, 1B or 1C	25-30 ft. lbs. (33-40 N m)
bolt 5/8 18 UNF 2A	10D	140-180 ft. lbs. (190-244 N m)
nut 3/4 16 UNF 2B	27A (TC, TB, TE)	175-255 ft. lbs. (237-305 N m)
Castle nut 1-20 UNEF 2B	27A (TJ)	250-300 ft. lbs. (339-407 N m)

- TC has two steel bushing internal of housing press first steel bushing 1.223 deep from housing face the second steel bushing press .03 below face

(Fabricate if considered necessary)

Figure 1 – TC, TS, TB & TE

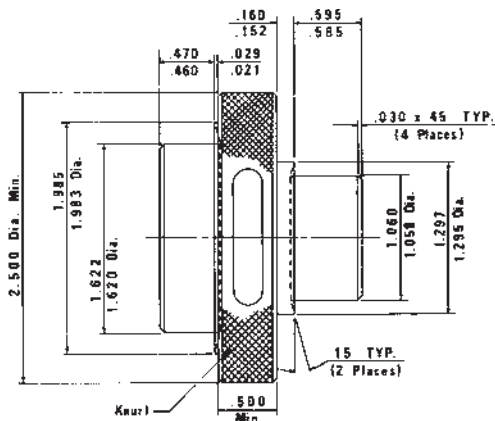

(Fabricate if considered necessary)

Figure 2 – TJ

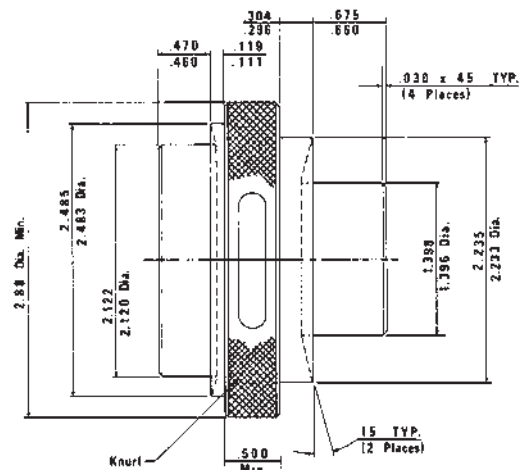

Typical Assembly

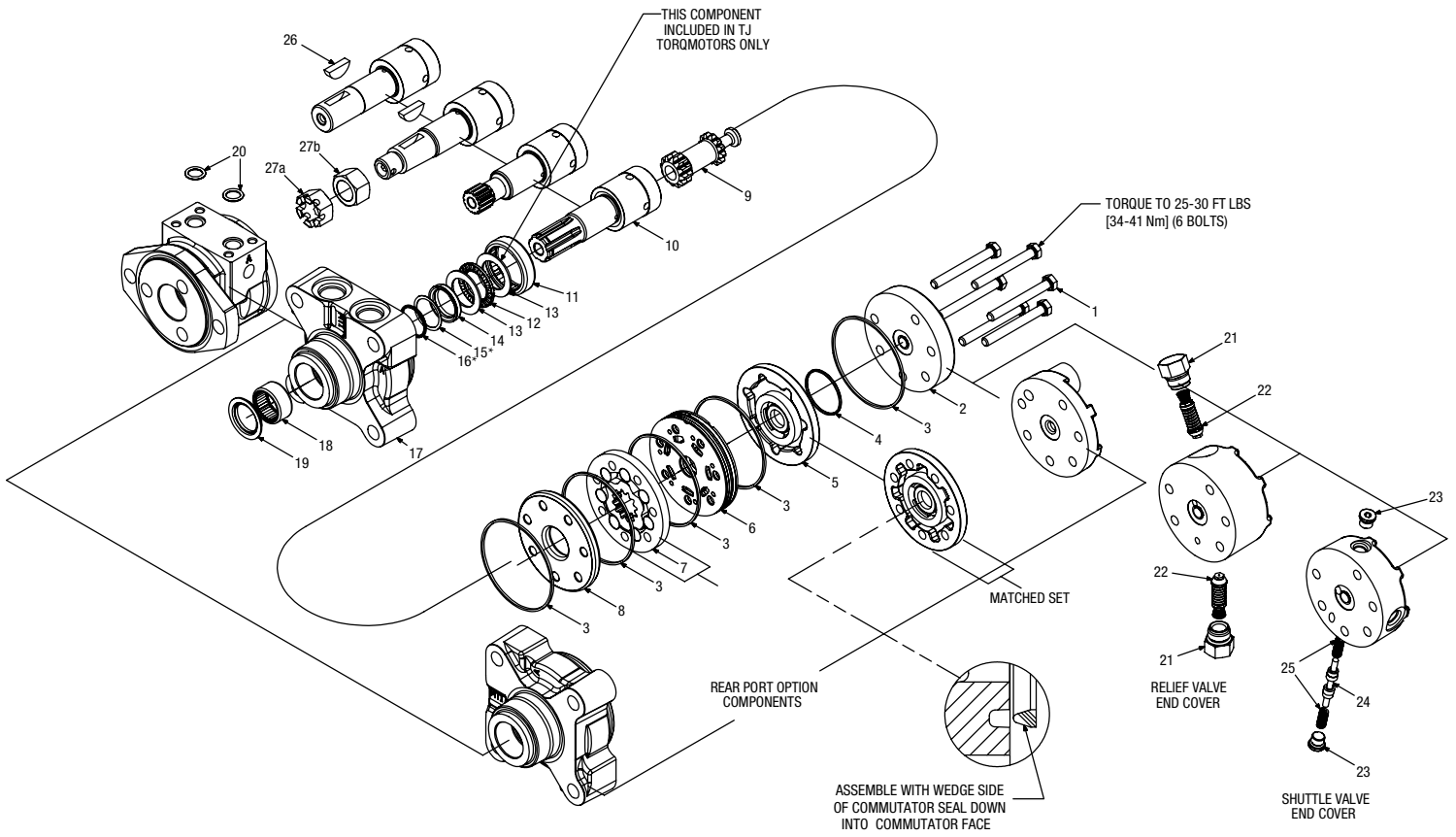

Item No. Description

- 1. Special Bolt (6)
- 2. End Cover
- 3. Seal Ring (5)
- 4. Seal Ring-Commutator
- 5. Commutator Assembly (Matched Set)
- 6. Manifold
- 7. Rotor Set (Matched Set)
- 8. Wear Plate
- 9. Drive Link
- 10. Coupling Shaft
- 11. Steel Bushing
- 12. Thrust Bearing
- 13. Thrust Washer (TJ Series Qty=2)
- 14. Shaft Seal

Item No. Description

- 15. *Back Up Washer (DateCode before 34824) [TJ excluded]
- 16. *Back Up Ring (DateCode before 34824) [TJ excluded]
- 17. Housing
- 18. Steel Bushing
- 19. Dirt & Water Seal
- 20. O-Ring (2)
- 21. Plug (2)
- 22. Relief Valve (2)
- 23. Plug (2)
- 24. Shuttle Valve
- 25. Spring (2)
- 26. Key
- 27a. Castle Nut
- 27b. Patch Nut

In July 2012, a change was made to our small frame (Series TC, TS, TB, TE and TJ) low speed high torque Torqmotors™.

The motors are comprised of six sections. There is a seal between each section to resist external leakage. The design of the motor dictates that it be assembled from front (shaft end) to rear. This means that the motor must be assembled shaft down. Some of the O-ring grooves in the current design are facing down during assembly. To keep the O-rings in place during assembly, they are coated with grease.

After assembly, this grease can seep out. This is often misdiagnosed as external hydraulic fluid leakage, causing the customer to think that the motor is faulty. It also can cause problems when the motor is painted.

To correct this problem, we have re-positioned the section O-ring grooves on five of the six parts (all but the front housing) so that the O-ring grooves are all facing up during assembly. It will now be possible to install the O-rings dry, eliminating the problem.

The part numbers of the five re-designed parts will change, but the complete model number (TE0080AS100AAAA etc) will not change. The change occurred on July 1, 2012. The new design is identified by the Julian date code on the motor. All TC, TS, TB, TE and TJ motors dated after Julian date 183-12 (183rd day of 2012) will be of the newer design. Seals and seal kits will be unaffected. Typical model number changes and seal groove locations are illustrated on page 15.

Made before July 1, 2012



Made on or after July 1, 2012



Notice: For individual part numbers for these series TC, TS, TB, TE and TJ prior to manufactory date code of 182-2012 please refer to the parts list on pages 18-26.

Torqmotor™ Exploded View

TC, TB, TE and TJ Assembly
before July 1, 2012

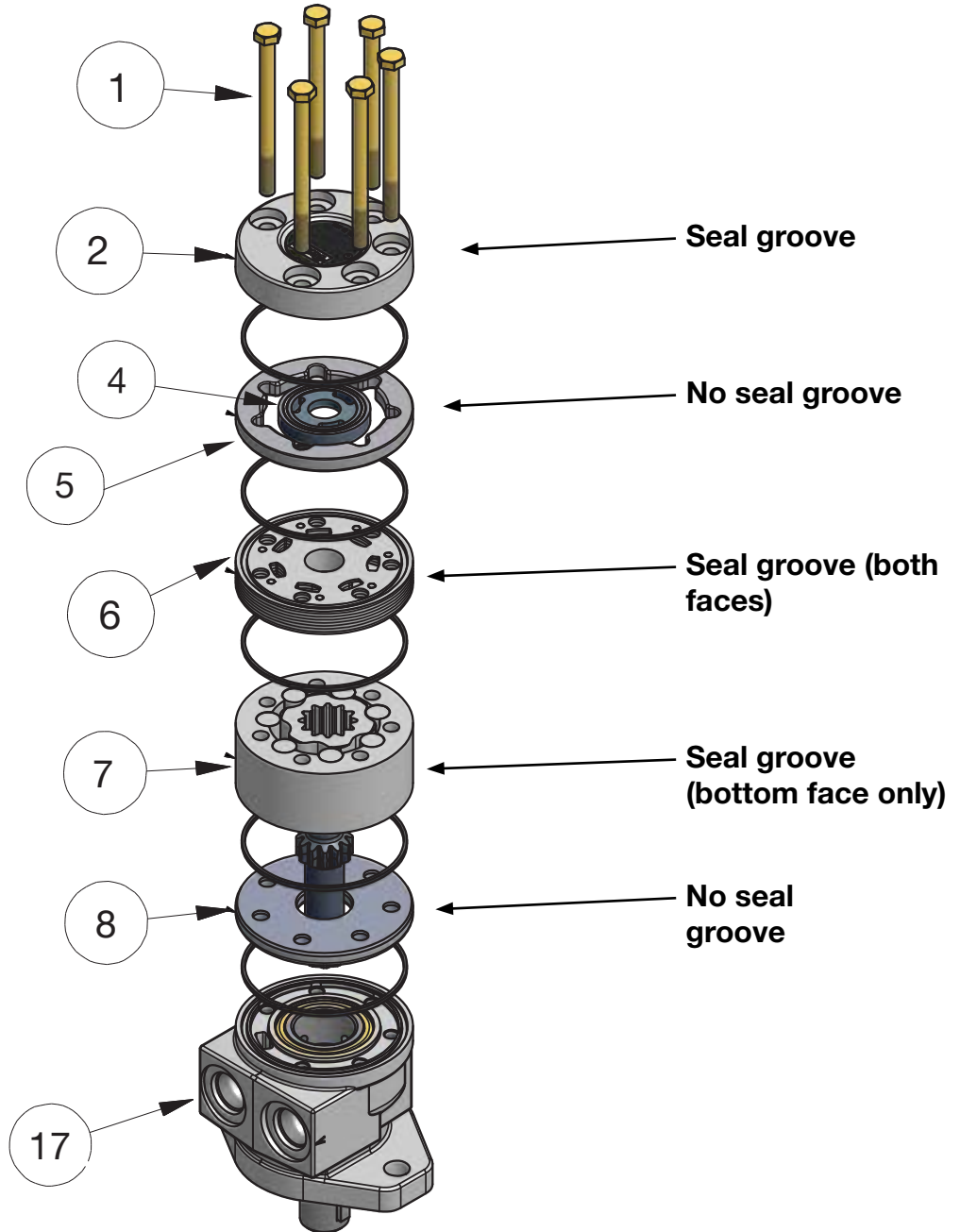

Torqmotor™ Exploded View

**TC, TB, TE and TJ Assembly
 on or after July 1, 2012**

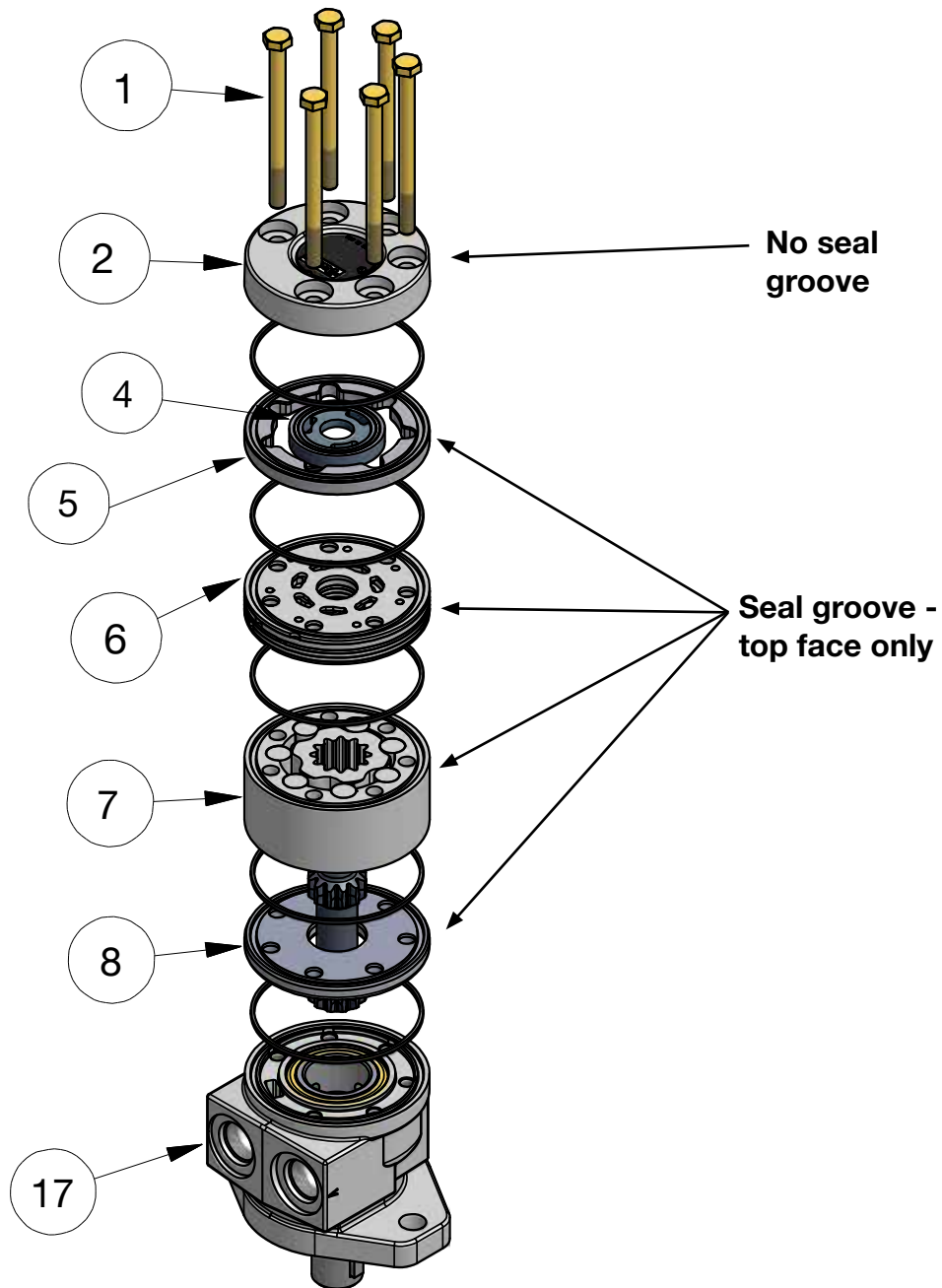

Item	QTY	New Part #	Old Part #	Description
8	1	477376	477341	Wear Plate
7	1	TE127003	MF127003	Rotor Set
6	1	TE015000	MF015000	Manifold
4 & 5	1	TE018000A1	MF018000A1	Commutator Assembly
2	1	TE016000	MF016007	End Cover

Torqmotor™ Exploded View

**TS Series Assembly
 before July 1, 2012**



Item No.	Description
1.	Special Bolt (6)
2.	End Cover
3.	Seal Ring-Commutator
4.	Seal Ring (5)
5 & 6.	Commutator Assembly (Matched Set)
7.	Manifold
8A.	Rotor Set (Matched Set)

Item No.	Description
9.	Wear Plate
10.	Drive Link
12.	Coupling Shaft
12A.	Stainless Key
13.	Steel Bushing
14.	Thrust Washer
15.	Thrust Bearing
16.	Shaft Seal

Item No.	Description
17.	*Back Up Ring (DateCode before 34824)
18.	Housing
19.	Steel Bushing
20.	Dirt & Water Seal
22.	Cover O-Ring
23.	Protective Cover
24.	Snap Ring
25.	*Back Up Washer (DateCode before 34824)

Torqmotor™ Exploded View

**TS Series Assembly
 on or after July 1, 2012**

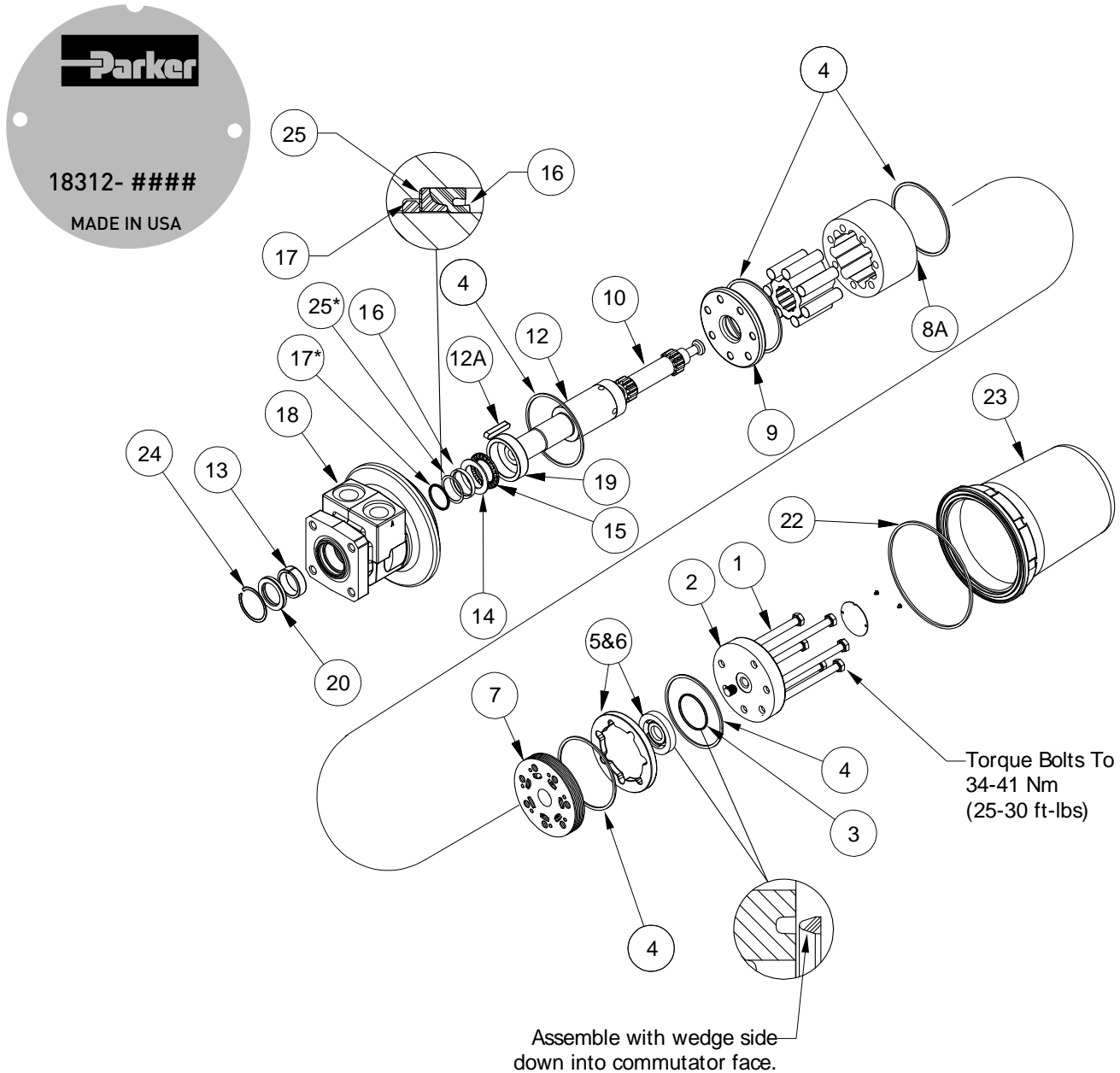

Item No. Description

- 1. Special Bolt (6)
- 2. End Cover
- 3. Seal Ring-Commutator
- 4. Seal Ring (5)
- 5 & 6. Commutator Assembly (Matched Set)
- 7. Manifold
- 8A. Rotor Set (Matched Set)

Item No. Description

- 9. Wear Plate
- 10. Drive Link
- 12. Coupling Shaft
- 12A. Stainless Key
- 13. Steel Bushing
- 14. Thrust Washer
- 15. Thrust Bearing
- 16. Shaft Seal

Item No. Description

- 17. *Back Up Ring (DateCode before 34824)
- 18. Housing
- 19. Steel Bushing
- 20. Dirt & Water Seal
- 22. Cover O-Ring
- 23. Protective Cover
- 24. Snap Ring
- 25. *Back Up Washer (DateCode before 34824)

Torqmotor™ Shaft Seal Letter

In late 2024, a design change was made to our small frame (Series TC, TS, TB, and TE) low speed high torque Torqmotors™

A new, single-piece, high-pressure shaft seal has been implemented in the TB, TC, TE, and TS family of motors. The previous design utilized a fully elastomeric seal, a back-up washer, and a back-up ring. With the new single-piece design, the backup ring and back-up washer have been eliminated and replaced with a one-piece, metal case seal that simplifies installation.

Motor Cross Section Comparing Legacy Shaft Seal Package and New Shaft Seal Package:

Legacy Design

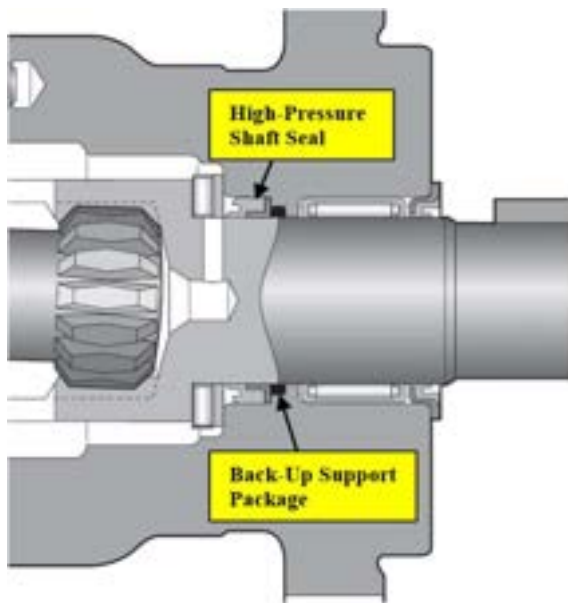

New Design

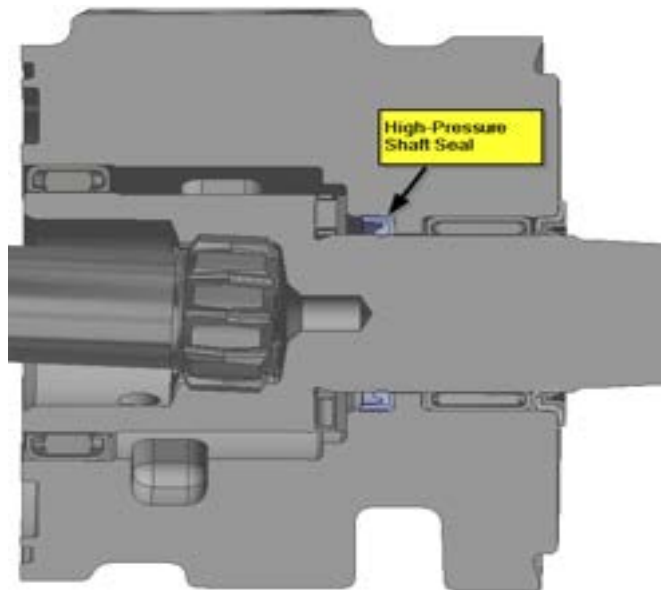

Made before Dec. 11, 2024



Made on or after Dec. 14, 2024



TC Service Parts List Chart

Chart Use Example:

TC0045AS010AAAB Torqmotor™ includes part numbers listed to the right of TC (SERIES), 0045 (DISP.), AS (MOUNTING/PORTING), 01(SHAFT), 0 (ROTATION), and AAAB (OPTION) shown in the left hand column of the chart.

Caution:

The charted component service information is for the Torqmotors listed only. Refer to the original equipment manufacturer of the equipment using the Torqmotor for assembly numbers not listed below.

SERIES	EXPLODED VIEW										
	ITEM #	5	6	8	11	13	12	16	18	19	15
	DESCRIPTION	COMMUTATOR & RING ASSY	MANIFOLD (SEE NOTE)	WEAR PLATE	STEEL BUSHING	THRUST WASHER	THRUST BEARING	BACKUP RING	STEEL BUSHING	DIRT & WATER SEAL	BACKUP WASHER
TC-	Service Part #	TE018000A1	TE015000	477376	069511*	028483	065066	028516**		478036	028552**

** Only in motors w/ DateCode before 34824 (*quantity 2)

EXPLODED VIEW (Select Item # Bolt Per Option Group)

DISPLACEMENT GROUP	ITEM #	1 OR	1A OR	1C	ROTOR THICKNESS	7A	7B	9	"L" Dim
	DISPLACEMENT (in3/rev)	BOLT # (BOLT LENGTH - 5 bolts required)			"L" DIM OF ROTOR THICKNESS	ROTOR SET	FREE RUNNING ROTOR SET††	DRIVE LINK	Overall Length
	0036-2.2	021356 (2.625)				.2750	TE017003	TE017005	MF013000
0045-2.7	021311 (2.750)	021443 (3.440)	021308 (3.875)		.3169	TE027003	TE027005	MF023000	3.021
0050-3.0	021311 (2.750)	021444 (3.500)	021308 (3.875)		.3751	TE037003	TE037005	MF033000	3.080
0065-4.0	021306 (2.875)	021358 (3.625)	021435 (4.000)		.5001	TE047003	TE047005	MF043000	3.206
0080-5.0	021382 (3.000)	021438 (3.750)	021359 (4.125)		.6258	TE057003	TE057005	MF053000	3.334
0100-6.0	021357 (3.125)	021308 (3.875)	021445 (4.250)		.7508	TE067003	TE067005	MF063000	3.460
0130-8.0	021307 (3.375)	021359 (4.125)	021439 (4.500)		1.0008	TE087003	TE087005	MF083000	3.712
0165-9.9	021358 (3.625)	021310 (4.375)	021384 (4.875)		1.2508	TE107003	TE107005	MF103000	3.969
0195-11.9	021308 (3.875)	021383 (4.625)	021465 (5.000)		1.5008	TE127003	TE127005	MF123000	4.215
0230-13.9	021359 (4.125)	021384 (4.875)	021460 (5.250)		1.7508	TE147003	TE147005	MF143000	4.467
0260-15.9	021310 (4.375)	021446 (5.125)	021467 (5.750)		2.0008	TE167003	TE167005	MF163000	4.718
0295-17.9	021383 (4.625)	021414 (5.375)	021467 (5.750)		2.2508	TE187003	TE187005	MF183000	4.970
0330-20.0	021384 (4.875)	021459 (5.625)	021448 (6.000)		2.5008	TE207003	TE207005	MF203000	5.220
0365-22.6	021460 (5.250)	021448 (6.000)	021469 (6.375)		2.8406	TE227003	N/A	MF223000	5.557
0390-24.0	021414 (5.375)	021449 (6.125)	021464 (6.531)		3.0030	TE247003	N/A	MF243000	5.716

†† Free running rotorset is not available in 0365 or 0390 displacements. *TC has two steel bushing press internal of housing.

HOUSING GROUP	Mounting Code Porting Code	EXPLODED VIEW				
		ITEM #	2	1217	120	
		DESCRIPTION	PORTING	END COVER	HOUSING SERVICE PART #	O-RING (2)
FRONT PORTING	AT-	SAE A (2 Bolt)	1/2" BSPF	TB016000	ML022012A2	
	AS-	SAE A (2 Bolt)	7/8" O-Ring	TB016000	ML022001A2	
	FS-	4 Bolt	7/8" O-Ring	TB016000	ML022005A2	
	AM-	SAE A (2 Bolt)	Manifold	TB016000	ML022008A2	032790
	FM-	4 Bolt	Manifold	TB016000	ML022006A2	032790
	AP-	SAE A (2 Bolt)	1/2" NPTF	TB016000	ML022002A2	
	FP-	4 Bolt	1/2" NPTF	TB016000	ML022007A2	
	FF-	4 Bolt	3/4" O-Ring	TB016000	ML022013A2	



TC Service Parts List Chart

Torqmotor™ Service Procedure TC, TS, TB, TE and TJ Series

EXPLODED VIEW		10		
ITEM #	DESCRIPTION	COUPLING SHAFT	WOODRUFF KEY	NUT
COUPLING SHAFT GROUP	01- Long 6B Snapwire Groove	ML019010		
	09- 1" Ø, 0.38 Pinhole, 0.55" from end	ML019005		
	10- 1" Short Woodruff Key 1/4" Tap	ML019002	038015 (1/4x1)	
	11- 1" Short 6B Spline, 1/4" Snapwire Groove	ML019001		
	13- 1" Long Woodruff Snapwire Groove	ML019006	038015 (1/4x1)	
	15- 1" Ø, 0.32 Pinhole 0.4" from end	ML019011		
	21- "-10 Code" plus Corrosion Resistant Nitrotec	ML019008		
	26- 25 mm Straight with 8 mm Keyway	ML019003	039047 (8mmx7mm)	
	28- 13 Tooth Spline 16/32 Pitch	ML019007		
	72- Short Woodruff Key 1/4" Tap	ML019009	038015 (1/4x1)	

EXPLODED VIEW			2							4		3	14	23	20	25	24 & 25
ITEM #	DESCRIPTION	BOLTS (5)	END COVER	COMMUTATOR SEAL	SEAL RING (5)	SHAFT SEAL	PLUG & O-RING ASSY	O-RING	SPRING	VALVE W/SPRING							
AAAB	No Paint	Item #1															
AAAC	Corrosion Resistant Paint	Item #1															
BBC	1740 PSI Internal Bidirectional Relief, No Paint	Item #1									^See Seal Kits Below						
BBCM	1200 PSI Internal Bidirectional Relief, No Paint	Item #1C	TE016006A7				411068A1 032750	401660	4100107								
BBCN	2030 PSI Internal Bidirectional Relief, No Paint	Item #1C	TE016006A31				411068A1 032750	401660	41001031								
BBCP	1450 PSI Internal Bidirectional Relief, No Paint	Item #1C	TE016006A5				411068A1 032750	401660	4100105								
BBC	1560 PSI Internal Bidirectional Relief, No Paint	Item #1C	TE016006A10				411068A1 032750	401660	41001010								
AAJW	Bidirectional Shuttle Valve (3:30), Black Paint	Item #1C Item #1A	TE016006A2 TE016003A1				411068A1 032750 036297 032750	401660 401660	4100102 415603								
AABW	Viton Shaft Seal, Double Paint	Item #1	TB016000														
AAAG	Viton Shaft Seals, Black Paint	Item #1	TB016000														
AABJ	Free Running Rotor Set, Black Paint	Item #1	TB016000														
AABK	Free Running Rotor Set, No Paint	Item #1	TB016000														

¹ Service housing assembly ITEM #17 with part number suffix-A2 includes ITEMS #11, #14, #13, and #12.

² Order (2) #032790 ITEM #20 for service housing assembly where manifold ports are used.

^Seal kit #SK000472 includes ITEMS #3, #4, #14, #15, #16, #19, a removal / installation tool, a grease pack, and a service bulletin.

Note: Items #15 & #16 to only be used if serviced motor contained them originally.

^Seal kit #SK000473 includes all of the items above, except for the installation / removal tool.

^Legacy Standard Seal kit #SK000090 (BunaN kit for Date Code prior to 34824) Will be available until quantities are depleted.

^Legacy Hi-Temp Seal kit #SK000091 (Viton kit for Date Code prior to 34824) Will be available until quantities are depleted.

NOTE: For reverse timed manifold, use TE015001.

* Speed sensor not available in TC Series.



TS Service Parts List Chart

Chart Use Example:

TS0045FS770AAXH Torqmotor™ includes part numbers listed to the right of TS (SERIES), 0045 (DISP.), FS (MOUNTING/PORTING), 77(SHAFT), 0 (ROTATION), and AAXH (OPTION) shown in the left hand column of the chart.

Caution:

The charted component service information is for the Torqmotors listed only. Refer to the original equipment manufacturer of the equipment using the Torqmotor for assembly numbers not listed below.

EXPLODED VIEW		5	7	9	13	14	15	17	19	20	25
SERIES	ITEM #	COMMUTATOR & RING ASSY	MANIFOLD (SEE NOTE)	WEAR PLATE	STEEL BUSHING	THRUST WASHER	THRUST BEARING	BACKUP RING	STEEL BUSHING	DIRT & WATER SEAL	BACKUP WASHER
	TS-	Service Part #	TE018000A1	TE015000	477376	069511	028483	065066	028516**	065071	478010

** Only used in motors w/ DateCode before 34824

DISPLACEMENT GROUP	EXPLODED VIEW		ROTOR THICKNESS		8A	8B	10	"L" Dim
	ITEM #	1						
	DISPLACEMENT (in ³ /rev)	BOLT # (BOLT LENGTH - 6 bolts required)	"L" DIM OF ROTOR THICKNESS	ROTOR SET	FREE RUNNING ROTOR SET ^{††}	DRIVE LINK	Overall Length	
0036-	2.2	021356 (2.625)	.2750	TE017003	TE017005	MF013000	2.975	
0045-	2.7	021311 (2.750)	.3169	TE027003	TE027005	MF023000	3.021	
0050-	3.0	021311 (2.750)	.3751	TE037003	TE037005	MF033000	3.080	
0065-	4.0	021306 (2.875)	.5001	TE047003	TE047005	MF043000	3.206	
0080-	5.0	021382 (3.000)	.6258	TE057003	TE057005	MF053000	3.334	
0100-	6.0	021357 (3.125)	.7508	TE067003	TE067005	MF063000	3.460	
0130-	8.0	021307 (3.375)	1.0008	TE087003	TE087005	MF083000	3.712	
0165-	9.9	021358 (3.625)	1.2508	TE107003	TE107005	MF103000	3.969	
0195-	11.9	021308 (3.875)	1.5008	TE127003	TE127005	MF123000	4.215	
0230-	13.9	021359 (4.125)	1.7508	TE147003	TE147005	MF143000	4.467	
0260-	15.9	021310 (4.375)	2.0008	TE167003	TE167005	MF163000	4.718	
0295-	17.9	021383 (4.625)	2.2508	TE187003	TE187005	MF183000	4.970	
0330-	20.0	021384 (4.875)	2.5008	TE207003	TE207005	MF203000	5.220	
0365-	22.6	021460 (5.250)	2.8406	TE227003	N/A	MF223000	5.557	
0390-	24.0	021414 (5.375)	3.0030	TE247003	N/A	MF243000	5.716	

†† Free running rotorset is not available in 0365 or 0390 displacements.

HOUSING GROUP	EXPLODED VIEW		2	18	23	22	3	4	16
	ITEM #		6 BOLT END COVER	HOUSING SERVICE PART	PROTECTIVE COVER	COVER O-RING	COMMUTATOR SEAL	O-RING (5)	SHAFT SEAL
	Mounting Code	Porting Code							
FS-	4 Bolt	7/8" O-Ring	TB016000	TS012201A2	420007				

*****^See Seal Kits Below*****

STAINLESS STEEL COUPLING SHAFT GROUP	EXPLODED VIEW		12	12A	24
	ITEM #		COUPLING SHAFT	STAINLESS KEY	RETAINING RING
	DESCRIPTION				
77-	1" Dia. 1/4" Square Key, 1/4"-20 Tap		TS019400	039053 (1/4x1/4x1.33)	401083

OPTION GROUP	DESCRIPTION
	AAXH
AAXW	Standard Motor with High-Temp Thrust Bearing

^Seal kit #SK000472 includes ITEMS #3, #4, #14, #15, #16, #17, #25, a removal / installation tool, a grease pack, and a service bulletin.

NOTE: Items #15 & #16 to only be used if serviced motor contained them originally.

^Seal kit #SK000473 includes all of the items above, except for the installation / removal tool.

^AAXH Legacy Seal Kit #SK000231 Includes ITEMS #3, #4 (qty6), #14, #15, #16, #17, #20, #22, #24, #25, and Service Bulletin #050088

^AAXW Legacy Seal Kit #SK000233 Includes all items above except ITEM #15 is a High-Temp Vespel Material instead of steel.



TB Service Parts List Chart

Chart Use Example:

TB0045AS010AAAAB Torqmotor™ includes part numbers listed to the right of TB (SERIES), 0045 (DISP.), AS (MOUNTING/PORTING), 01(SHAFT), 0 (ROTATION), and AAAB (OPTION) shown in the left hand column of the chart.

Caution:

The charted component service information is for the Torqmotors listed only. Refer to the original equipment manufacturer of the equipment using the Torqmotor for assembly numbers not listed below.

SERIES	EXPLODED VIEW										
	ITEM #	5	6	8	11	13	12	16	18	19	15
	DESCRIPTION	COMMUTATOR & RING ASSY	MANIFOLD (SEE NOTE)	WEAR PLATE	BRONZE BUSHING	THRUST WASHER	THRUST BEARING	BACKUP RING	"DU" BEARING	DIRT & WATER SEAL	BACKUP WASHER
TB-	Service Part #	TE018000A1*	TE015000	477376	069511	028483	065066	028516**	065505	478036	028552**

** Only in motors w/ DateCode before 34824

DISPLACEMENT GROUP	EXPLODED VIEW (Select Item # Bolt Per Option Group)				ROTOR				
	ITEM #	1 OR	1A OR	1C	THICKNESS	7A	7B	9	"L" Dim
	DISPLACEMENT (in3/rev)	BOLT # (BOLT LENGTH - 5 bolts required)†			"L" DIM OF ROTOR THICKNESS	ROTOR SET	FREE RUNNING ROTOR SET††	DRIVE LINK	Overall Length
0036-2.2	021356 (2.625)				.2750	TE017003	TE017005	MF013000	2.975
0045-2.7	021311 (2.750)	021443 (3.440)	021308 (3.875)		.3169	TE027003	TE027005	MF023000	3.021
0050-3.0	021311 (2.750)	021444 (3.500)	021308 (3.875)		.3751	TE037003	TE037005	MF033000	3.080
0065-4.0	021306 (2.875)	021358 (3.625)	021435 (4.000)		.5001	TE047003	TE047005	MF043000	3.206
0080-5.0	021382 (3.000)	021438 (3.750)	021359 (4.125)		.6258	TE057003	TE057005	MF053000	3.334
0100-6.0	021357 (3.125)	021308 (3.875)	021445 (4.250)		.7508	TE067003	TE067005	MF063000	3.460
0130-8.0	021307 (3.375)	021359 (4.125)	021439 (4.500)		1.0008	TE087003	TE087005	MF083000	3.712
0165-9.9	021358 (3.625)	021310 (4.375)	021384 (4.875)		1.2508	TE107003	TE107005	MF103000	3.969
0195-11.9	021308 (3.875)	021383 (4.625)	021465 (5.000)		1.5008	TE127003	TE127005	MF123000	4.215
0230-13.9	021359 (4.125)	021384 (4.875)	021460 (5.250)		1.7508	TE147003	TE147005	MF143000	4.467
0260-15.9	021310 (4.375)	021446 (5.125)	021467 (5.750)		2.0008	TE167003	TE167005	MF163000	4.718
0295-17.9	021383 (4.625)	021414 (5.375)	021467 (5.750)		2.2508	TE187003	TE187005	MF183000	4.970
0330-20.0	021384 (4.875)	021459 (5.625)	021448 (6.000)		2.5008	TE207003	TE207005	MF203000	5.220
0365-22.6	021460 (5.250)	021448 (6.000)	021469 (6.375)		2.8406	TE227003	N/A	MF223000	5.557
0390-24.0	021414 (5.375)	021449 (6.125)	021464 (6.531)		3.0030	TE247003	N/A	MF243000	5.716

† Bolts for TB Series front ported units are the same as rear ported units if you are using the same displacement.

†† Free running rotorset is not available in 0365 or 0390 displacements.

FRONT PORTING	EXPLODED VIEW					
	Mounting Code	Porting Code	ITEM #	2	1,217	A20
	DESCRIPTION			END COVER	HOUSING SERVICE PART #	O-RING (2)
MS-	Standard (4 Bolt)	7/8" O-Ring		TB016000	MF022014A2	
AS-	SAE A (2 Bolt)	7/8" O-Ring		TB016000	MF022001A2	
FS-	4 Bolt	7/8" O-Ring		TB016000	MF022003A2	
AM-	SAE A (2 Bolt)	Manifold		TB016000	MF022004A2	032790
FM-	4 Bolt	Manifold		TB016000	MF022005A2	032790
MM-	Standard (4 Bolt)	Manifold		TB016000	MF022049A2	032790
AP-	SAE A (2 Bolt)	1/2" NPTF		TB016000	MF022006A2	
FP-	4 Bolt	1/2" NPTF		TB016000	MF022007A2	
AT-	SAE A (2 Bolt)	1/2" BSPF		TB016000	MF022011A2	
BP-	SAE B (2 Bolt)	1/2" NPTF		TB016000	MF022073A2	

HOUSING GROUP	EXPLODED VIEW				
	Mounting Code	Porting Code	ITEM #	2	1,817
	DESCRIPTION			END COVER	HOUSING SERVICE PART #
AR-	SAE A (2 Bolt)	Rear (3/4"-16 SAE O-Ring)		TE016001	MF022008A2
FR-	4 Bolt	Rear (3/4"-16 SAE O-Ring)		TE016001	MF022010A2
BR-	SAE B (2 Bolt)	Rear (3/4"-16 SAE O-Ring)		TE016001	MF022076A2



TB Service Parts List Chart

Torqmotor™ Service Procedure TC, TS, TB, TE and TJ Series

EXPLODED VIEW		10		
ITEM #	DESCRIPTION	COUPLING SHAFT	WOODRUFF KEY	NUT
01-	Long 6B Snapwire Groove	MF019007		
09-	1" Ø, 0.38 Pinhole, 0.55" from end	MF019000		
10-	1" Short Woodruff Key 1/4" Tap	MF019006	038015 (1/4x1)	
11-	1" Short 6B Spline, 1/4" Snapwire Groove	MF019003		
12-	1" Tapered (Short)	MF019004	038015 (1/4x1)	025136
13-	1" Long Woodruff Snapwire Groove	MF019005	038015 (1/4x1)	
14-	1" Ø, Double Pinhole	MF019001		
15-	1" Ø, 0.32 Pinhole 0.4" from end	MF019002		
21-	"-10 Code" plus Corrosion Resistant	MF019008		
22-	25 mm Straight with 7 mm Keyway, 6 mm Tap	MF019009	039041	
23-	Short 6B Spline 5/16" Tap	MF019010		
25-	1" Tapered SAE	MF019011	038015 (1/4x1)	025136
26-	25 mm Straight with 8 mm Keyway	MF019012	039047 (8mmx7mm)	
28-	13 Tooth Spline	MF019014		
29-	1" Taper 3/4-16 Thread	MF019015		
33-	1" Tapered, 3/16 Key, 3/4-16 Thd	MF019016	038014 (3/16x3/4)	025156 Slotted Nut
40-	Short Wood, 6mm Tap	MF019021		
50-	1" w.406 dia pinhole .62 from end 1/4-20 Tap	MF019032		
66-	26 code plus Nitrotec C	MF019044		
69-	25mm Straight w/8mm key 8mm Tap Stainless Steel	MF019412		
70-	1" Dia. Short Woodkey 1/4" Tap Stainless Steel	MF019406		

EXPLODED VIEW		2 4 3 14 23 20 25 24 & 25								
ITEM #	DESCRIPTION	BOLTS (5)	END COVER	COMMUTATOR SEAL	SEAL RING (5)	SHAFT SEAL	PLUG & O-RING ASSY	O-RING	SPRING	VALVE W/SPRING
AAAB	No Paint	Item #1								
AAAC	Corrosion Resistant Paint	Item #1		^See Seal Kits Below						
BBCB	1740 PSI Internal Bidirectional Relief, No Paint	Item #1C	TE016006A7				411068A1	032750	401660	4100107
BBCM	1200 PSI Internal Bidirectional Relief, No Paint	Item #1C	TE016006A31				411068A1	032750	401660	41001031
BBCN	2030 PSI Internal Bidirectional Relief, No Paint	Item #1C	TE016006A5				411068A1	032750	401660	4100105
BBCP	1450 PSI Internal Bidirectional Relief, No Paint	Item #1C	TE016006A10				411068A1	032750	401660	41001010
BBCP	1450 PSI Internal Bidirectional Relief, No Paint	Item #1C	TE016006A10				411068A1	032750	401660	4100102
BBCP	1450 PSI Internal Bidirectional Relief, No Paint	Item #1C	TE016006A10				411068A1	032750	401660	41001010
AAJV	Bidirectional Shuttle Valve (3:30), Black Paint	Item #1A	TE016003A1				036297	032750	401660	415603

Note: Rear ported TB motors have 5 bolts at the back end cover.

¹ Service housing assembly ITEM #17 with part number suffix-A2 includes ITEM #11, #12, #13, #14 and #18.

² Order (2) #032790 ITEM #20 for service housing assembly where manifold ports are used.

^Seal kit #SK000472 includes ITEMS #3, #4, #14, #15, #16, #19, a removal / installation tool, a grease pack, and a service bulletin.

NOTE: Items #15 & #16 to only be used if serviced motor contained them originally.

^Seal kit #SK000473 includes all of the items above, except for the installation / removal tool.

^Legacy Standard Seal kit #SK000090 (BunaN kit for Date Code prior to 34824) Will be available until quantities are depleted.

^Legacy Hi-Temp Seal kit #SK000091 (Viton kit for Date Code prior to 34824) Will be available until quantities are depleted.

NOTE: For reverse timed manifold, use TE015001.

* Commutator set for rear ported units TE018001A1.



TE Service Parts List Chart

Chart Use Example:

TE0045AS010AAAB Torqmotor™ includes part numbers listed to the right of TE (SERIES), 0045 (DISP.), AS (MOUNTING/PORTING), 01(SHAFT), 0 (ROTATION), and AAAB (OPTION) shown in the left hand column of the chart.

Caution:

The charted component service information is for the Torqmotors listed only. Refer to the original equipment manufacturer of the equipment using the Torqmotor for assembly numbers not listed below.

EXPLODED VIEW											
SERIES	ITEM #	5	6	8	11	13	12	16	18	19	15
	DESCRIPTION	COMMUTATOR & RING ASSY	MANIFOLD (SEE NOTE)	WEAR PLATE	REAR RADIAL BEARING	THRUST WASHER	THRUST BEARING	BACKUP RING	FRONT RADIAL BEARING	DIRT & WATER SEAL	BACKUP WASHER
TE-	Service Part #	TE018000A1*	TE015000	477376	069512	028483	065066	028516**	065506	478036	028552**

** Only in motors w/ DateCode before 34824

EXPLODED VIEW (Select Item # Bolt Per Option Group)				ROTOR				
ITEM #	1 OR	1A OR	1C	THICKNESS	7A	7B	9	"L" Dim
DISPLACEMENT (in3/rev)	1 - BOLT # (BOLT LENGTH - 6 bolts required) [†] 1A & 1C BOLT # (BOLT LENGTH - 5 bolts required)			"L" DIM OF ROTOR THICKNESS	ROTOR SET	FREE RUNNING ROTOR SET ^{††}	DRIVE LINK	Overall Length
0036-2.2	021356 (2.625)			.2750	TE017003	TE017005	MF013000	2.975
0045-2.7	021311 (2.750)	021443 (3.440)	021308 (3.875)	.3169	TE027003	TE027005	MF023000	3.021
0050-3.0	021311 (2.750)	021444 (3.500)	021308 (3.875)	.3751	TE037003	TE037005	MF033000	3.080
0065-4.0	021306 (2.875)	021358 (3.625)	021435 (4.000)	.5001	TE047003	TE047005	MF043000	3.206
0080-5.0	021382 (3.000)	021438 (3.750)	021359 (4.125)	.6258	TE057003	TE057005	MF053000	3.334
0100-6.0	021357 (3.125)	021308 (3.875)	021445 (4.250)	.7508	TE067003	TE067005	MF063000	3.460
0130-8.0	021307 (3.375)	021359 (4.125)	021439 (4.500)	1.0008	TE087003	TE087005	MF083000	3.712
0165-9.9	021358 (3.625)	021310 (4.375)	021384 (4.875)	1.2508	TE107003	TE107005	MF103000	3.969
0195-11.9	021308 (3.875)	021383 (4.625)	021465 (5.000)	1.5008	TE127003	TE127005	MF123000	4.215
0230-13.9	021359 (4.125)	021384 (4.875)	021460 (5.250)	1.7508	TE147003	TE147005	MF143000	4.467
0260-15.9	021310 (4.375)	021446 (5.125)	021467 (5.750)	2.0008	TE167003	TE167005	MF163000	4.718
0295-17.9	021383 (4.625)	021414 (5.375)	021467 (5.750)	2.2508	TE187003	TE187005	MF183000	4.970
0330-20.0	021384 (4.875)	021459 (5.625)	021448 (6.000)	2.5008	TE207003	TE207005	MF203000	5.220
0365-22.6	021460 (5.250)	021448 (6.000)	021469 (6.375)	2.8406	TE227003	N/A	MF223000	5.557
0390-24.0	021414 (5.375)	021449 (6.125)	021464 (6.531)	3.0030	TE247003	N/A	MF243000	5.716

[†] Bolts for TE Series front ported units are the same as rear ported units if you are using the same displacement.

^{††} Free running rotorset is not available in 0365 or 0390 displacements.

FRONT PORTING	EXPLODED VIEW						SPEED SENSOR		
	Mounting Code	Porting Code	ITEM #	2	1 ⁴ 17	17	1 ² 20	6 BOLT HSG SERVICE PART #	SENSOR
	DESCRIPTION		MOUNTING	PORTING	6 BOLT END COVER	5 BOLT HSG SERVICE PART #	6 BOLT HSG SERVICE PART #	O-RING (2)	
MS-	Standard (4 Bolt)	7/8" O-Ring	TE016000		TE016000	MF022014A1	MF022214A1		MF022314A1 455063
AS-	SAE A (2 Bolt)	7/8" O-Ring	TE016000		TE016000	MF022001A1	MF022201A1		MF022301A1 455063
US-	Wheel Mount	7/8" O-Ring	TE016000		TE016000	MF022002A1	MF022202A1		MF022302A1 455063
FS-	4 Bolt	7/8" O-Ring	TE016000		TE016000	MF022003A1	MF022203A1		MF022303A1 455063
AM-	SAE A (2 Bolt)	Manifold	TE016000		TE016000	MF022004A1	MF022204A1	032790	MF022304A1 455063
FM-	4 Bolt	Manifold	TE016000		TE016000	MF022005A1	MF022205A1	032790	
MM-	Standard (4 Bolt)	Manifold	TE016000		TE016000	MF022049A1	MF022249A1	032790	
AP-	SAE A (2 Bolt)	1/2" NPTF	TE016000		TE016000	MF022006A1	MF022206A1		MF022306A1 455063
FP-	4 Bolt	1/2" NPTF	TE016000		TE016000	MF022007A1	MF022207A1		MF022307A1 455063
AT-	SAE A (2 Bolt)	1/2" BSPF	TE016000		TE016000	MF022011A1	MF022211A1		

REAR PORTING	EXPLODED VIEW					SPEED SENSOR	
	Mounting Code	Porting Code	ITEM #	2	1 ⁴ 17	5 BOLT HSG SERVICE PART #	SENSOR
	DESCRIPTION		MOUNTING	PORTING	5 BOLT END COVER	5 BOLT HSG SERVICE PART #	
MR-	Standard (4 Bolt)	Rear Port (3/4"-16 SAE O-Ring)	TE016001		TE016001	MF022021A1	
UR-	Small Wheel Mount	Rear Port (3/4"-16 SAE O-Ring)	TE016001		TE016001	MF022009A1	N/A 455063
FR-	4 Bolt Mount	Rear Port (3/4"-16 SAE O-Ring)	TE016001		TE016001	MF022010A1	
AR-	SAE A (2 Bolt)	Rear Port (3/4"-16 SAE O-Ring)	TE016001		TE016001	MF022008A1	N/A 455063

NOTE: Rear ported TE motors always have 5 bolts at the back end cover.



TE Service Parts List Chart

Torqmotor™ Service Procedure TC, TS, TB, TE and TJ Series

EXPLODED VIEW					SPEED SENSOR
ITEM #		10			10
	DESCRIPTION	COUPLING SHAFT	WOODRUFF KEY	NUT	COUPLING SHAFT
COUPLING SHAFT GROUP	01- Long 6B Snapwire Groove	MF019007			MF019307
	09- 1" Ø, 0.38 "Pinhole, 0.55" from end	MF019000			
	10- 1" Short Woodruff Key 1/4" Tap	MF019006	038015 (1/4x1)		MF019306
	11- 1" Short 6B Spline, 1/4" Snapwire Groove	MF019003			MF019303
	12- 1" Tapered (Short)	MF019004	038015 (1/4x1)	025136	MF019304
	13- 1" Long Woodruff Snapwire Groove	MF019005	038015 (1/4x1)		MF019305
	14- 1" Ø, Double Pinhole	MF019001			
	15- 1" Ø, 0.32 "Pinhole 0.4" from end	MF019002			
	21- "-10 Code" plus Corrosion Resistant	MF019008			MF019308
	22- 25 mm Straight Shaft with 7 mm Keyway	MF019009	039041		
	25- 1" Tapered SAE	MF019011	038015 (1/4x1)	025136	MF019311
	26- 25 mm Straight with 8 mm Keyway	MF019012	039047 (8mmx7mm)		MF019312
	28- 13 Tooth Spline	MF019014			MF019314
	33- 1" Tapered, 3/16 Key, 3/4-16 Thd	MF019016	038014 (3/16x3/4)	025156 Slotted Nut	
	69- 25mm Straight with 8mm (stainless steel)	MF019412			
	70- 1" dia short, woodruff key, 1/4 tap (stainless steel)	MF019406			
	75- 1" dia long, woodruff key, 1/4 tap (stainless steel)	MF019446			

EXPLODED VIEW							
ITEM #		*1, 1A, 1C	2	2	4	3	14
	DESCRIPTION	BOLT	5 BOLT END COVER	6 BOLT END COVER	COMMUTATOR SEAL	SEAL RING (5)	SHAFT SEAL SENSOR
AAAA	Standard Black Paint	Item #1		TE016000			
AAAB	No Paint	Item #1		TE016000			
AAAC	Corrosion Resistant Paint	Item #1		TE016000			
AABJ	Free Running Rotor Set	Item #1		TE016000			
					^See Seal Kits Below		
BBCK	1740 PSI Internal Bidirectional Relief, No Paint	Item #1C	TE016006A7	N/A			
BBCM	1200 PSI Internal Bidirectional Relief, No Paint	Item #1C	TE016006A31	N/A			
BBCN	2030 PSI Internal Bidirectional Relief, No Paint	Item #1C	TE016006A5	N/A			
BBCP	1450 PSI Internal Bidirectional Relief, No Paint	Item #1C	TE016006A10	N/A			
BBC T	1560 PSI Internal Bidirectional Relief, No Paint	Item #1C	TE016006A2	N/A			
AAJV	Bidirectional Shuttle Valve (3:30), Black Paint	Item #1A	TE016003A1	N/A			
FSAA	Speed Sensor, Black Paint	Item #1		TE016000			455063
FSAB	Speed Sensor, No Paint	Item #1		TE016000			455063
FSAH	Speed Sensor, Castle Nut, No Paint	Item #1		TE016000			455063
FSAJ	Speed Sensor, Castle Nut, Black Paint	Item #1		TE016000			455063

¹ Service housing assembly ITEM #17 with part number suffix-A2 includes ITEM #11, #12, #13, #14 and #18.

² Select the required bolt number in designated "DISPLACEMENT GROUP" under bolt ITEM #1, 1A, 1B or 1C shown in designated "OPTION GROUP"

³ Castle Nut #025156 is required if the designated "OPTION GROUP" is AAAF, AAAN, or AAAU.

⁴ Order (2) #032790 ITEM #17A for service housing assembly where manifold ports are used.

^Seal kit #SK000472 includes ITEMS #3, #4, #14, #15, #16, #19, a removal / installation tool, a grease pack, and a service bulletin.

NOTE: Item #15 & #16 to only be used if serviced motor contained them originally.

^Seal kit #SK000473 includes all of the items above, except for the installation / removal tool.

^Legacy Standard Seal kit #SK000090 (BunaN kit for Date Code prior to 34824) Will be available until quantities are depleted.

^Legacy Hi-Temp Seal kit #SK000091 (Viton kit for Date Code prior to 34824) Will be available until quantities are depleted.

NOTE: For reverse timed manifold use part number TE015001.

* Commutator set for rear ported unit TE018001A1.



TJ Service Parts List Chart

Chart Use Example:

TJ0045US080AAAB Torqmotor™ includes part numbers listed to the right of TJ (SERIES), 0045 (DISP.), US (MOUNTING/PORTING), 08(SHAFT), 0 (ROTATION), and AAAB (OPTION) shown in the left hand column of the chart.

Caution:

The charted component service information is for the Torqmotors listed only. Refer to the original equipment manufacturer of the equipment using the Torqmotor for assembly numbers not listed below.

EXPLODED VIEW											
SERIES	ITEM #	'5	6	8	'11	'13	'12	16	'18	19	15
	DESCRIPTION	COMMUTATOR ASSEMBLY	MANIFOLD (SEE NOTE)	WEAR REAR PLATE	REAR RADIAL BEARING	THRUST WASHER(2)	THRUST BEARING	BACKUP RING	FRONT RADIAL BEARING	DIRT & WATER SEAL	BACKUP WASHER
TJ-	Service Part #	TE018000A1	TE015000	477376	069513	028348	069030	028515**	068027	478035	029118**

EXPLODED VIEW (Select Item # Bolt Per Option Group)				ROTOR				
ITEM #	1 OR	1A OR	1C	THICKNESS	7A	7B	9	"L" Dim
DISPLACEMENT (in3/rev)	BOLT # (BOLT LENGTH - 6 bolts required) †			"L" DIM OF ROTOR THICKNESS	ROTOR SET	FREE RUNNING ROTOR SET††	DRIVE LINK	Overall Length
0036-2.2	021356 (2.625)			.2750	TE017003	TE017005	MF013000	2.975
0045-2.7	021311 (2.750)	021443 (3.440)	021308 (3.875)	.3169	TE027003	TE027005	MF023000	3.021
0050-3.0	021311 (2.750)	021444 (3.500)	021308 (3.875)	.3751	TE037003	TE037005	MF033000	3.080
0065-4.0	021306 (2.875)	021358 (3.625)	021435 (4.000)	.5001	TE047003	TE047005	MF043000	3.206
0080-5.0	021382 (3.000)	021438 (3.750)	021359 (4.125)	.6258	TE057003	TE057005	MF053000	3.334
0100-6.0	021357 (3.125)	021308 (3.875)	021445 (4.250)	.7508	TE067003	TE067005	MF063000	3.460
0130-8.0	021307 (3.375)	021359 (4.125)	021439 (4.500)	1.0008	TE087003	TE087005	MF083000	3.712
0165-9.9	021358 (3.625)	021310 (4.375)	*	1.2508	TE107003	TE107005	MF103000	3.969
0195-11.9	021308 (3.875)	021383 (4.625)	021465 (5.000)	1.5008	TE127003	TE127005	MF123000	4.215
0230-13.9	021359 (4.125)	021384 (4.875)	021460 (5.250)	1.7508	TE147003	TE147005	MF143000	4.467
0260-15.9	021310 (4.375)	021446 (5.125)	021467 (5.750)	2.0008	TE167003	TE167005	MF163000	4.718
0295-17.9	021383 (4.625)	021414 (5.375)	*	2.2508	TE187003	TE187005	MF183000	4.970
0330-20.0	021384 (4.875)	021459 (5.625)	021448 (6.000)	2.5008	TE207003	TE207005	MF203000	5.220
0365-22.6	021460 (5.250)	021448 (6.000)	*	2.8406	TE227003	N/A	MF223000	5.557
0390-24.0	021414 (5.375)	021449 (6.125)	021464 (6.531)	3.0030	TE247003	N/A	MF243000	5.716

† Bolts for TE Series front ported units are the same as rear ported units if you are using the same displacement.

†† Free running rotorset is not available in 0365 or 0390 displacements.

** Only in motors w/ DateCode before 34824

TJ Service Parts List Chart

HOUSING GROUP Mounting Code Porting Code	EXPLODED VIEW			COUPLING SHAFT GROUP
	ITEM #		18	
	DESCRIPTION		SERVICE HOUSING ASSY	
	MOUNTING	PORTING		
US-	Wheel Mount (4 Bolt)	7/8"-14 SAE O-Ring	MP012002A1	08- 1 1/4" Tapered MP019000 038016 (5/16x1) 025126

OPTION GROUP	EXPLODED VIEW						
	ITEM #		1, 1A, 1C	2	4	3	14
	DESCRIPTION		BOLT	END COVER	COMMUTATOR SEAL	SEAL RING (5)	SHAFT SEAL
AAAB	No Paint		ITEM #1	TE016000	032861	032821	032817
AAAC	Corrosion Resistant Paint		ITEM #1	TE016000	032861	032821	032817
AABJ	Free Running Rotor Set		ITEM #1	TE016000	032861	032821	032817
BBCK	1740 PSI Internal Bidirectional Relief, No Paint		ITEM #1C	TE016006A7	032861	032821	032817
BBCM	1200 PSI Internal Bidirectional Relief, No Paint		ITEM #1C	TE016006A31	032861	032821	032817
BBCN	2030 PSI Internal Bidirectional Relief, No Paint		ITEM #1C	TE016006A5	032861	032821	032817
BBCP	1450 PSI Internal Bidirectional Relief, No Paint		ITEM #1C	TE016006A10	032861	032821	032817
BBCT	1560 PSI Internal Bidirectional Relief, No Paint		ITEM #1C	TE016006A2	032861	032821	032817
AAJV	Bidirectional Shuttle Valve (3:30), Black Paint		ITEM #1A	TE016004A1	032861	032821	032817

¹ Service housing assembly ITEM #17 with part number suffix-A1 includes ITEM #11, #12, #13 and #18.

² Order (2) #032790 ITEM #17A for service housing assembly where manifold ports are used.

³ Nut #025113 is required if the designated "OPTION GROUP" is AAAF, AAAN, or AAAU.

Standard seal kit #SK000146 includes ITEMS #3 (qty 6), #4, #14, #16, #15, #19, a grease pack, and service bulletin.

High Temp seal kit #SK000148 includes all of the items above, except ITEM #14 is a Viton shaft seal instead of BunaN.

NOTE: For reverse timed manifold, use TE015001.

ITEMS	Legacy Motors		New Seals	
	SK000090	SK000091	SK000472	SK000473
Back Up Ring	028516	028516	028516	028516
Backup Washer	028552	028552	028552	028552
Shaft seal	032378	032871	032379	032379
Commutator seal	032861	032861	032861	032861
Sealing rings	032821	032822	032821	032821
Lubricant	406018	406018	406018	406018
Dirt/water seal	478036	478036	478036	478036
Removal Tool			900018	
Installation Tool			900017	
Snap Ring			3432	

NOTE: TJ Series Seals are unchanged.

Disassembly and Inspection

Preparation Before Disassembly

- Before you disassemble the Torqmotor™ unit or any of its components read this entire manual. It provides important information on parts and procedures you will need to know to service the Torqmotor™.
- Determine the type of end construction from the alternate views shown on the exploded view.
- The TC, TS, TB & TE Torqmotors™ will have a 3.66 inch (92.9 mm) main body outside diameter and five or six 5/16-24 UNF 2A cover bolts. The TJ Torqmotors™ will have a 3.66 inch (92.9 mm) main body outside diameter and six 5/16-24 UNF 2A cover bolts.
- Refer to “Tools and Materials Required for Services” section for tools and other items required to service the Torqmotor™ and have them available.
- Thoroughly clean off all outside dirt, especially from around fittings and hose connections, before disconnecting and removing the Torqmotor™. Remove rust or corrosion from coupling shaft.
- Remove coupling shaft connections and hose fittings and immediately plug port holes and fluid lines.
- Remove the Torqmotor™ from system, drain it of fluid and take it to a clean work surface.
- Clean and dry the Torqmotor™ before you start to disassemble the unit.
- As you disassemble the Torqmotor™ clean all parts, except seals, in clean petroleum-based solvent, and blow them dry.

WARNING: petroleum-base solvents are flammable. Be extremely careful when using any solvent. Even a small explosion or fire could cause injury or death.

WARNING: WEAR EYE PROTECTION AND BE SURE TO COMPLY WITH OSHA OR OTHER MAXIMUM AIR PRESSURE REQUIREMENTS.

CAUTION: Never steam or high pressure wash hydraulic components. Do not force or abuse closely fitted parts.

- Keep parts separate to avoid nicks and burrs.
- Discard all seals and seal rings as they are removed from the Torqmotor™. Replace all seals, seal rings and any damaged or worn parts with genuine Parker or OEM approved service parts.

Disassembly and Inspection

Reference Exploded Assembly View

Place Torqmotor in a vise

1. Place the Torqmotor™ in a soft jawed vise, with coupling shaft (10) pointed down and the vise jaws clamping firmly on the sides of the housing (17) mounting flange or port bosses. SEE FIGURE 3. Remove manifold port O-Rings (20) if applicable.

WARNING

WARNING: IF THE TORQMOTOR™ IS NOT FIRMLY HELD IN THE VISE, IT COULD BE DISLODGED DURING THE SERVICE PROCEDURES, CAUSING INJURY.

Scribe alignment mark & loosen valve plugs

2. Scribe an alignment mark down and across the Torqmotor™ components from end cover (2) to housing (17) to facilitate reassembly orientation where required. Loosen two shuttle or relief valve plugs (21, 23) for disassembly later if included in end cover. 3/16 or 3/8 inch Allen wrench or 1 inch hex socket required. SEE FIGURES 4 & 5.

Remove special bolts & inspect bolts

3. Remove the seven special ring head bolts (1, 1A, 1B or 1C) using an appropriate 1/2 inch size socket. Inspect bolts for damaged threads, or sealing rings, under the bolt head. Replace damaged bolts. SEE FIGURES 6-9.



Figure 3



Figure 4



Figure 5



Figure 7



Figure 8



Figure 9



Figure 6

Disassembly and Inspection

Remove end cover & inspect bolts

4. Remove end cover assembly (2). SEE FIGURE 10. After July 2012, motors no longer have section seal ring located in the end cover (2).



Figure 10

NOTE

NOTE: Refer to the appropriate “alternate cover construction” on the exploded view to determine the end cover construction being serviced.

Remove plugs and valves

5. If the end cover (2) is equipped with shuttle valve or relief valve (22,24) components, remove the two previously loosened plugs (21,23). SEE FIGURE 11.



Figure 11

CAUTION

CAUTION: Be ready to catch the shuttle valve or relief valve components that will fall out of the end cover valve cavity when the plugs are removed.

NOTE

NOTE: O-ring (20) is not included in seal kits but serviced separately if required.

NOTE

NOTE: The orifice plug in the end cover (2) must not be removed as they are serviced as an integral part of the end cover.

Wash & inspect end cover

6. Thoroughly wash end cover (2) in proper solvent and blow dry. Be sure the end cover valve apertures, including the internal orifice plug, are free of contamination. Inspect end cover for cracks and the bolt head recesses for good bolt head sealing surfaces. Replace end cover as necessary.



Figure 12

NOTE

NOTE: A polished pattern (not scratches) on the cover from rotation of the commutator (5) is normal. Discoloration would indicate excess fluid temperature, thermal shock, or excess speed and require system investigation for cause and close inspection of end cover, commutator, manifold, and rotor set.

Remove & inspect commutator ring

7. Remove commutator ring seal (3) and discard. SEE FIGURE 12. Remove commutator ring (5). Inspect commutator ring for cracks, or burrs. SEE FIGURE 13.



Figure 13

Disassembly and Inspection

Remove & inspect commutator

8. Remove commutator (5) and seal ring (4)
Remove seal ring from commutator, using an air hose to blow air into ring groove until seal ring is lifted out and discard seal ring. Inspect commutator for cracks or burrs, wear, scoring, spalling or brinelling. If any of these conditions exist, replace commutator and commutator ring as a matched set. SEE FIGURE 14 & 15.



Figure 14



Figure 15

Remove manifold

9. Remove manifold seal ring (3) and discard. SEE FIGURE 16. Remove the manifold (6) and inspect for cracks surface scoring, brinelling or spalling. Replace manifold if any of these conditions exist. SEE FIGURE 17. A polished pattern on the ground surface from commutator or rotor rotation is normal.



Figure 16

NOTE

NOTE: The manifold is constructed of plates bonded together to form an integral component not subject to further disassembly for service. Compare configuration of both sides of the manifold to ensure that same surface is reassembled against the rotor set.



Figure 17

Disassembly and Inspection**NOTE**

NOTE: A polished pattern on the wear plate from rotor rotation is normal. SEE FIGURE 18

Remove & inspect rotor set & wearplate

- Remove rotor set (7) and wearplate (8), together to retain the rotor set in its assembled form, maintaining the same rotor vane to stator contact surfaces. SEE FIGURE 19. The drive link (9) may come away from the coupling shaft (10) with the rotor set, and wearplate. You may have to shift the rotor set on the wearplate to work the drive link out of the rotor (7) and wearplate (8). SEE FIGURE 20. Inspect the rotor set in its assembled form for nicks, scoring, or spalling on any surface and for broken or worn splines. If the rotor set component requires replacement, the complete rotor set must be replaced as it is a matched set. Inspect the wearplate for cracks, brinelling, or scoring. Discard seal ring (3) that is between the rotor set and wearplate.



Figure 18



Figure 19

NOTE

NOTE: The rotor set (7) components may become disassembled during service procedures. Marking the surface of the rotor and stator that is facing UP, with etching ink or grease pencil before removal from Torqmotor™ will ensure correct reassembly of rotor into stator and rotor set into Torqmotor™. Marking all rotor components and mating spline components for exact repositioning at assembly will ensure maximum wear life and performance of rotor set and Torqmotor™.

Check rotor, vane clearance

- Place rotor set (7) and wear plate (8) on a flat surface and center rotor in stator such that two rotor lobes (180 degrees apart) and a roller vane centerline are on the same stator centerline. Check the rotor lobe to roller vane clearance with a feeler gage at this common centerline. If there is more than .005 inches (0.13 mm) of clearance, replace rotor set. SEE FIGURE 21 & 22.

NOTE

NOTE: If rotor set (7) has two stator halves and two sets of seven vanes, check the rotor lobe to roller vane clearance at both ends of rotor.



Figure 20



Figure 21

Disassembly and Inspection

12. If wear plate is still in place then remove the wear plate seal ring (3) and discard.



Figure 22

Remove & inspect drive link

13. Remove drive link (9) from coupling shaft (10) if it was not removed with rotor set and wear plate. Inspect drive link for cracks and worn or damaged splines. No perceptible lash (play) should be noted between mating spline parts. SEE FIGURE 23.



Figure 23

Remove seal ring from housing

14. Remove and discard seal ring (3) from housing (17). SEE FIGURE 24.



Figure 24

Check coupling shaft for rust or corrosion

15. Check exposed portion of coupling shaft (10) to be sure you have removed all signs of rust and corrosion which might prevent its withdrawal through the seal and bearing. Crocus cloth or fine emery paper may be used. SEE FIGURE 25. Remove any key (26) or nut (27a,27b).



Figure 25

Disassembly and Inspection

Remove & inspect coupling shaft

- Remove coupling shaft (10), by pushing on the output end of shaft. SEE FIGURE 26 & 27. Inspect coupling shaft bearing and seal surfaces for spalling, nicks, grooves, severe wear or corrosion and discoloration. Inspect for damaged or worn internal and external splines or keyway. SEE FIGURE 28. Replace coupling shaft if any of these conditions exist.



Figure 26



Figure 27

NOTE

NOTE: Minor shaft wear in seal area is permissible. If wear exceeds .020 inches (0.51 mm) diametrically, replace coupling shaft.

NOTE

NOTE: A slight “polish” is permissible in the shaft bearing areas. Anything more would require coupling shaft replacement.

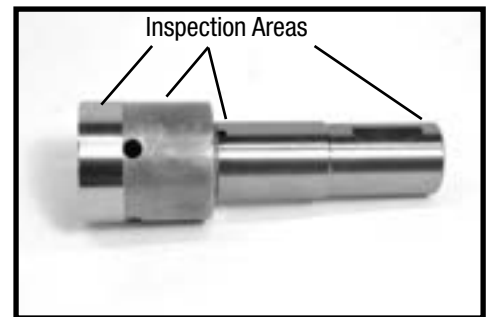

Figure 28

Inspect housing assembly

- Inspect housing (17) assembly for cracks, the machined surfaces for nicks, burrs, brinelling or corrosion. Remove burrs that can be removed without changing dimensional characteristics. Inspect tapped holes for thread damage. SEE FIGURE 29. If the housing is defective in these areas, discard the housing assembly.



Figure 29

Remove & inspect thrust washer & thrust bearing

- Remove thrust bearing (12) and thrust washer (13). Inspect for wear, brinelling, corrosion and a full complement of retained rollers. SEE FIGURE 30.

The TJ series has a thrust bearing (12) sandwiched between two thrust washers (13) that cannot be removed from the housing (17) unless bearing (14) is removed for replacement.



Figure 30

Disassembly and Inspection

Remove shaft seal, backup ring and backup washer*

Shaft Seal removal instructions for motors (TJ excluded) w/ Date Code on or after 34824 on next page.

- Remove shaft seal (14), backup washer* (15) and back up ring* (16) from housing (17). Discard both. SEE FIGURE 31. *NOTE: Parts 14 & 15 only in motors (TJ excluded) w/ Date Code before 34824

In the TJ series, the shaft seal (14), backup washer (15) and backup ring (16) must be removed by working them around unseated thrust washers (13) and thrust bearing (12) and out of the housing. Discard seal and washers. SEE FIGURES 31A, 31B & 31C.



Figure 31



Figure 31A



Figure 31B



Figure 31C

Inspect housing bearing/bushing

- If the housing (17) assembly has passed inspection to this point, inspect the housing bearings/bushings (11) and (18) and if they are captured in the housing cavity the thrust washer (13) and thrust bearing (12). The bearing rollers must be firmly retained in the bearing cages, but must rotate and orbit freely. All rollers and thrust washers must be free of brinelling and corrosion. SEE FIGURE 32. A bearing, bushing, or thrust washer that does not pass inspection must be replaced. If the housing has passed this inspection the disassembly of the Torqmotor™ is completed.



Figure 32

Remove bearings or bushings & thrust washers

- If the bearings, bushing or thrust washers must be replaced use a suitable size bearing puller to remove bearing/bushings (18) and (11) from housing (17) without damaging the housing. Remove thrust washer (13) and thrust bearing (12) if they were previously retained in the housing by bearing (11). SEE FIGURES 33.



Figure 33

Remove dirt & water seal

- Remove housing (17) from vise, invert it and remove and discard dirt & water seal (19). A blind hole bearing or seal puller is required. SEE FIGURE 34.



Figure 34

THE DISASSEMBLY OF TORQMOTOR™ IS COMPLETED.

Torqmotor™ Assembly**Removal Instructions for shaft seals in TC, TS, TB, and TE motors w/ Date Code on or after 34824:**

1. With a disassembled motor, remove the coupling shaft from the motor housing.
 2. Using the supplied snap ring, install the snap ring in the area shown on Figure 1.
 3. Using tool 900018, press the snap ring slowly in the direction shown in Figure 1.
- The snap ring will expand and catch the seal to remove it from the housing.

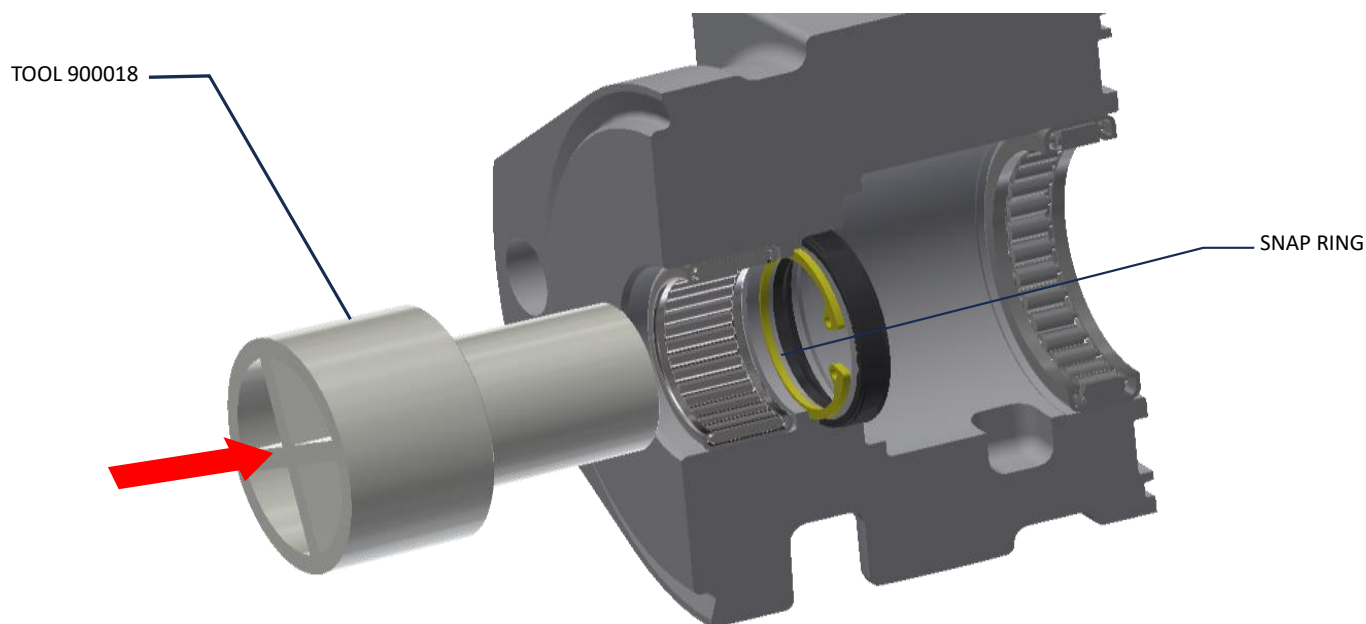

Figure 1

Torqmotor™ Assembly

- Replace all seals and seal rings with new ones each time you reassemble the Torqmotor™ unit. Lubricate all seals and seal rings with SAE 10W40 oil or clean grease before assembly.
- **NOTE: Individual seals and seal rings as well as a complete seal kit are available. SEE FIGURE 35. The parts should be available through most OEM parts distributors or Parker approved Torqmotor™ distributors. (Contact your local dealer for availability).**
- **NOTE: Unless otherwise indicated, do not oil or grease parts before assembly.**
- Wash all parts in clean petroleum-based solvents before assembly. Blow them dry with compressed air. Remove any paint chips from mating surfaces of the end cover, commutator set, manifold rotor set, wear plate and housing and from port and sealing areas.

WARNING

WARNING: SINCE THEY ARE FLAMMABLE, BE EXTREMELY CAREFUL WHEN USING ANY SOLVENT. EVEN A SMALL EXPLOSION OR FIRE COULD CAUSE INJURY OR DEATH.

WARNING

WARNING: WEAR EYE PROTECTION AND BE SURE TO COMPLY WITH OSHA OR OTHER MAXIMUM AIR PRESSURE REQUIREMENTS.

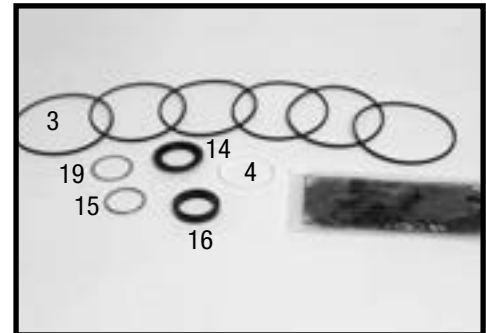

Figure 35 seal kit

Press in outer bearing/bushing

1. If the housing (17) bearing components were removed for replacement, thoroughly coat and pack a **new** outer bearing/bushing (18) with clean corrosion resistant grease recommended in the material section. Press the new bearing/bushing into the counterbore at the mounting flange end of the housing, using the appropriate sized bearing mandrel such as described in Figure 1 or Figure 2 which will control the bearing/ bushing depth.

TC, TS, TB and TE Torqmotor™ housings require the use of bearing mandrel shown in Figure 1 to press bearing/ bushing (18) into the housing to a required depth of .151/.161 inches (3.84/4.09 mm) from the end of the bearing counterbore. SEE FIGURE 36A.

TJ Torqmotor™ housings require the use of the bearing mandrel shown in Figure 2 to press bearing (18) into the housing to a required depth of .290/.310 inches (7.37/7,87 mm) from the outside end of the bearing counterbore. SEE FIGURE 36B.



Figure 36A



Figure 36B

Torqmotor™ Assembly

NOTE **NOTE:** Bearing mandrel must be pressed against the lettered end of bearing shell. Take care that the housing bore is square with the press base and the bearing/bushing is not cocked when pressing a bearing/bushing into the housing.

CAUTION **CAUTION:** If the bearing mandrel specified in the “Tools and Materials Required for Servicing” section is not available and alternate methods are used to press in bearing/bushing (11) and (18) the bearing/bushing depths specified must be achieved to insure adequate bearing support and correct relationship to adjacent components when assembled.

CAUTION **CAUTION:** Because the bearing/bushings (11) and (18) have a press fit into the housing they must be discarded when removed. They must not be reused.

Press in dirt & water seal 2. Press a **new** dirt and water seal (19) into the housing (17) outer bearing counterbore. The dirt and water seal (19) must be pressed in until its' flange is flush against the housing. SEE FIGURE 37A.

The TJ series dirt and water seal (19) must be pressed in the lip facing out and until the seal is flush to .020 inches (.51 mm) below the end housing. SEE FIGURE 37B.



Figure 37A

Press in inner bearing/bushing 3. The inner housing bearing/bushing (11) can now be pressed into its counterbore in housing (17) flush to .03 inch (.76 mm) below the housing wear plate contact face. Use the opposite end of the bearing mandrel that was used to press in the outer bearing/bushing (18). Reference Figure 1, “Tools and Materials Required for Servicing” section. SEE FIGURE 38.



Figure 37B



Figure 38

Torqmotor™ Assembly**Place housing assembly into vise**

- Place housing (17) assembly into a soft jawed vise with the coupling shaft bore down, clamping against the mounting flange. SEE FIGURE 39.



Figure 39

Assemble backup washers* & shaft seal

Shaft Seal installation instructions for motors w/ Date Code after 34824 (TJ excluded) on next page.

- TC, TS, TB & TE Torqmotors™ assemble a **new** backup ring* (16), **new** backup washer* (15) and **new** seal (14) with the seal lip facing toward the inside of Torqmotor™ (see Figure 57B), into their respective counterbores in housing (17) if they were not assembled in procedure 1. *NOTE: Parts 14 & 15 only in motors w/ Date Code before 34824 (TJ excluded).



Figure 40

The TJ Torqmotor™ housing (17) requires that you assemble a **new** backup washer (15) & backup ring (16), **new** seal (14), with the lip facing to the inside of Torqmotor (see figure 57A), **new** thrust washer (13), **new** thrust bearing (12) and a **new** second thrust washer (13) in that order before pressing in the inner housing bearing (11). SEE FIGURES 40A & 40B.



Figure 40A

When these components are in place, press **new** bearing (11) into the housing (17) to a depth of .03 inches (.76 mm) max for TJ below the housing wear plate contact face. Use the opposite end of the bearing mandrel used to press in outer bearing (18). Reference Figure 2, in the "Tools and Materials Required for Servicing" section. SEE FIGURE 40C.



Figure 40B



Figure 40C

Torqmotor™ Assembly**Installation Instructions for shaft seals in TC, TS, TB, and TE motors w/ Date Code on or after 34824:**

1. Clean the motor housing seal bore thoroughly to remove any debris.
2. Fully lubricate a new shaft seal with clean hydraulic oil and place on the installation tool 900017 as shown in Figure 2.



Figure 2

3. If having an older housing (Date Code prior to 34824), install the backup ring and washer as before.
4. Align the seal and installation tool 900017 with the seal bore as shown in Figure 3.
5. Align tool 900018 with installation tool 900017 and apply force to installation tool 900018 until the seal is fully pressed into the bore. *An arbor press is recommended to provide sufficient force.*
6. Carefully remove press tool 900018 and the installation tool 900017 from the seal, taking caution not to damage the seal.

Seal installation is now complete.

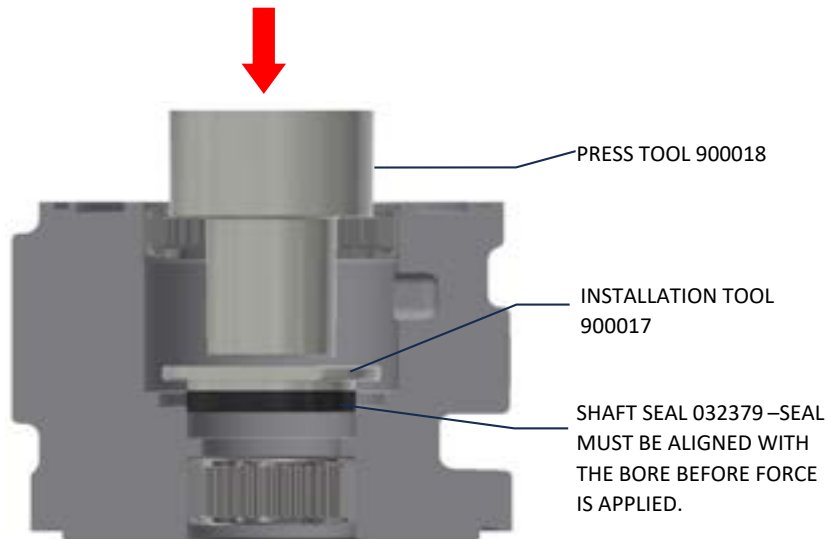

Figure 3

For a TJ Torqmotor™ that did not require replacing the bearing, assemble a **new** backup washer (15) & backup ring (16) and a **new** seal (14), with the lip facing to the inside of Torqmotor (see figure 57A), by working them around unseated thrust washers (13) and thrust bearing (12). SEE FIGURE 40D.



Figure 40D

Assemble thrust washer & bearing

6. Assemble thrust washer (13) then thrust bearing (12) that was removed from the Series TC, TB, TS or TE Torqmotor™. SEE FIGURE 41.

NOTE

NOTE: TC, TS, TB and TE Torqmotors™ require one thrust washer (13) with thrust bearing (12). The coupling shaft will be seated directly against the thrust bearing.



Figure 41

Install coupling shaft

7. Be sure that a generous amount of clean corrosion resistant grease has been applied to the lower (outer) housing bearing/bushing (18). Install the coupling shaft (10) into housing (17), seating it against the thrust bearing (12) in TC, TS, TB and TE Series housings. SEE FIGURE 42.

CAUTION

CAUTION: The outer bearing (18) is not lubricated by the system's hydraulic fluid. Be sure it is thoroughly packed with the recommended grease, Parker Gear grease specification #045236, E/M Lubricant #K-70M.



Figure 42

NOTE

NOTE: Mobil Mobilith SHC ® 460
NOTE: A 102 Tube (P/N 406010) is included in each seal kit.

NOTE

NOTE: The coupling shaft (10) will be flush or just below the housing wear surface on the TC, TS, TB, TE & TJ Torqmotors™ when properly seated. The coupling shaft must rotate smoothly on the thrust bearing package.

Torqmotor™ Assembly**Insert seal ring**

8. Apply a small amount of clean grease to a **new** seal ring (3) and insert it into the housing (17) seal ring groove. SEE FIGURE 43.



Figure 43

Install drive link

9. Install drive link (9) the long splined end down into the coupling shaft (10) and engage the drive link splines into mesh with the coupling shaft splines. SEE FIGURE 44.

NOTE

NOTE: Use any alignment marks put on the coupling shaft and drive link before disassembly to assemble the drive link splines in their original position in the mating coupling shaft splines.



Figure 44

NOTE

NOTE: One or two alignment studs screwed finger tight into housing (17) bolt holes, approximately 180 degrees apart, will facilitate the assembly and alignment of components as required in the following procedures. The studs can be made by cutting off the heads of either 3/8-24 UNF 2A or 5/16-24 UNF 2A bolts as required that are over .5 inch (12.7 mm) longer than the bolts (1, 1A, 1B or 1C) used in the Torqmotor™.

Assemble wear plate

10. Assemble wear plate (8) over the drive link (9) and alignment studs onto the housing (17). SEE FIGURE 45.

Apply a small amount of clean grease to a new seal ring and insert into the groove of the wear plate.



Figure 45

Torqmotor™ Assembly

Install the assembled rotor set

11. Install the assembled rotor set (7) onto wear plate (8) with rotor counterbore and seal ring side down and the splines into mesh with the drive link splines.

Apply clean grease to a **new** seal ring (3) and assemble it in the seal ring groove in the rotor set.



Figure 46

NOTE

NOTE: It may be necessary to turn one alignment stud out of the housing (17) temporarily to assemble rotor set (7) or manifold (6) over the drive link.

NOTE

NOTE: If necessary, go to the appropriate, "Rotor Set Component Assembly Procedure."

NOTE

NOTE: The rotor set rotor counterbore side must be down against wear plate for drive link clearance and to maintain the original rotor-drive link spline contact. A rotor set without a counterbore and that was not etched before disassembly can be reinstalled using the drive link spline pattern on the rotor splines if apparent, to determine which side was down.

Assemble manifold

12. Assemble the manifold (6) over the alignment studs and drive link (9) and onto the rotor set. Be sure the correct manifold surface is against the rotor set.

Apply grease to a **new** seal ring (3) and insert it in the seal ring groove exposed on the manifold. SEE FIGURE 47.

NOTE: The manifold (6) is made up of several plates bonded together permanently to form an integral component. The manifold surface that must contact the rotor set has its series of irregular shaped cavities on the largest circumference or circle around the inside diameter. The polished impression left on the manifold by the rotor set is another indication of which surface must contact the rotor set.



Figure 47

Torqmotor™ Assembly**Assemble commutator ring**

13. Assemble the commutator ring (5) over alignment studs onto the manifold. SEE FIGURE 48. After June 2012, add seal ring to commutator ring.



Figure 48

Assemble seal & commutator

14. Assemble a **new** commutator seal ring (3) flat side up, into commutator (5) and assemble commutator over the end of drive link (9) onto manifold (6) with seal ring side up. SEE FIGURE 49.



Figure 49

Assemble shuttle valve parts into end cover

15. If shuttle valve components items #23, #24, #25 were removed from the end cover (2) turn a plug (23) with a **new** o-ring (20), loosely into one end of the valve cavity in the end cover. Insert a spring (25) the valve (24) and the second spring (25) into the other end of the valve cavity. Turn the second plug (23) with a **new** o-ring (20) loosely into the end cover valve cavity. 3/16 inch Allen wrench required. SEE FIGURE 50.



Figure 50

Torqmotor™ Assembly

Assemble relief valve parts in end cover

16. If relief valve components items #21, #22 were removed from the end cover (2) assemble a **new** o-ring (20) on the two plugs (21). Assemble a two piece relief valve (22) in each of the plugs, with the large end of the conical spring into the plug first and the small nut of the other valve piece in the small end of the conical spring. Turn each of the plug and relief valve assemblies into the end cover loosely to be torqued later. 3/8 inch Allen or 1 inch Hex socket required. SEE FIGURE 51 & 52.



Figure 51



Figure 52

Assemble end cover

17. Assemble end cover over the alignment studs and onto the commutator set. SEE FIGURE 53 & 54. If the end cover has only 5 bolt holes be sure the cover holes are aligned with the 5 threaded holes in housing (17). The correct 5 bolt end cover bolt hole relationship to housing port bosses is shown in FIGURE 53. After June 2012, end cover no longer has o-ring section seal.



Figure 53

NOTE

NOTE: If the end cover has a valve (22, 24) or has five bolt holes, use the line you previously scribed on the cover to radially align the end cover into its original position.



Figure 54

Torqmotor™ Assembly**Assemble
cover bolts**

18. Assemble the 5 or 6 special bolts (1, 1A, 1B or 1C) and screw in finger tight. Remove and replace the two alignment studs with bolts after the other bolts are in place. Alternately and progressively tighten the bolts to pull the end cover and other components into place with a final torque of 25-30 ft. lbs. (34-41 N m) for the five TC, TS, TB or six TE Series 5/16 24 threaded bolts or six TJ bolts. SEE FIGURE 55.



Figure 55

NOTE

NOTE: The special bolts required for use with the relief or shuttle valve (22, 24) end cover assembly (2) are longer than the bolts required with standard and cover assembly. Refer to the individual service parts lists or parts list charts for correct service part number if replacement is required.

**Torque the
valve plugs**

19. Torque the two shuttle valve plug assemblies (23) in end cover assembly to 9-12 ft. lbs. (12-16 N m) if cover is so equipped. SEE FIGURE 56.

Torque the two relief valve plug assemblies (21) in end cover assembly to 45-55 ft. lbs. (61-75 N m) if cover is so equipped.



Figure 56

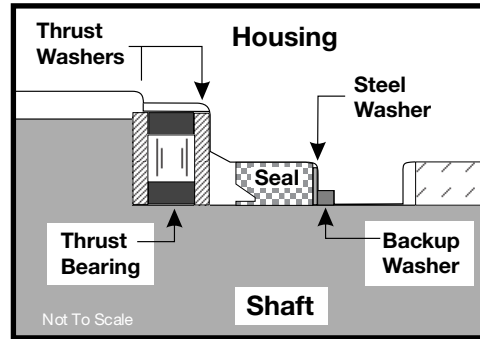

Figure 57A TJ Series

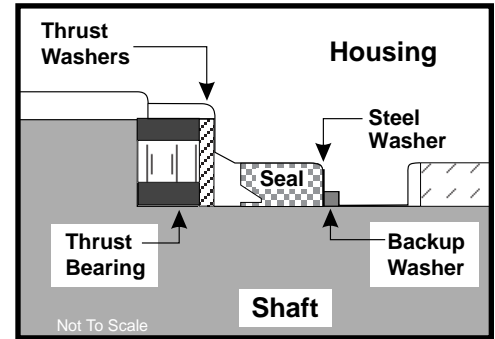

Figure 57B TC, TS, TB, TE Series

THE ASSEMBLY OF THE TORQMOTOR™ IS NOW COMPLETE EXCEPT FOR WOODRUFF KEY, NUT, WASHER, BOLT, LOCKWASHER, RETAINER RING or PORT O-RINGS AT INSTALLATION IF APPLICABLE. PROCEED TO FINAL CHECKS SECTION.

Rotor Set Component Assembly**One Piece Stator Construction**

A disassembled rotor (7) stator and vanes that cannot be readily assembled by hand can be assembled by the following procedures.

Assemble stator 1. Place stator (7) onto wear plate (8) with seal ring (3) side up, after following Torqmotor™ assembly procedures 1 through 11. Be sure the seal ring is in place. SEE FIGURE 58.

Insert two bolts 2. If assembly alignment studs are not being utilized, align stator bolt holes with wear plate and housing bolt holes and turn two bolts (1, 1A, 1B or 1C) finger tight into bolt holes approximately 180 degrees apart to retain stator and wear plate stationary.

Assemble rotor 3. Assemble the rotor (7), counterbore down if applicable, into stator, and onto wear plate (8) with rotor splines into mesh with drive link (9) splines. SEE FIGURE 59.

NOTE

NOTE: If the manifold side of the rotor was etched during Torqmotor disassembly, this side should be up. If the rotor is not etched and does not have a counterbore, use the drive link spline contact pattern apparent on the rotor splines to determine the rotor side that must be against the wear plate.

Assemble vanes 4. Assemble six vanes, or as many vanes that will readily assemble into the stator vane pockets. SEE FIGURE 60.

CAUTION

CAUTION: Excessive force used to push the rotor vanes into place could shear off the coating applied to the stator vane pockets.

Assemble full complement of vanes

5. Grasp the output end of coupling shaft (10) with locking pliers or other appropriate turning device and rotate coupling shaft, drive link and rotor to seat the rotor and the assembled vanes into stator, creating the necessary clearance to assemble the seventh or full complement of seven vanes. Assemble the seven vanes using minimum force.

Remove two assembled bolts

6. Remove the two assembled bolts (1, 1A, 1B or 1C) if used to retain stator and wear plate.

Go to Torqmotor™ assembly procedure #13, to continue Torqmotor™ assembly.



Figure 58



Figure 59



Figure 60

Rotor Set Component Assembly

Two Piece Stator Construction

A disassembled rotor set (7) that cannot be readily assembled by hand and has a two piece stator can be assembled by the following procedures.

Assemble stator halves 1. Place stator half onto wear plate (8) with seal ring (3) side up, after following Torqmotor™ assembly procedures 1 through 11. Be sure the seal ring is in place. SEE FIGURE 61.



Figure 61

Insert two alignment studs 2. Align stator bolt holes with wear plate and housing bolts and turn two alignment studs finger tight into bolt holes approximately 180 degrees apart to retain stator half and wear plate stationary. SEE FIGURE 46.

Assemble rotor 3. Assemble rotor, counterbore down into stator half, and onto wear plate (8) with rotor splines into mesh with drive link (9) splines.



Figure 62

NOTE

NOTE: Use any marking you applied to rotor set components to reassemble the components in their original relationship to ensure ultimate wear life and performance.

Assemble vanes 4. Assemble six vanes, or as many vanes that will readily assemble into the stator vane pockets. SEE FIGURE 62.

CAUTION

CAUTION: Excessive force used to push the rotor vanes into place could shear off the coating applied to the stator vane pockets.



Figure 63

Assemble full complement of vanes 5. Grasp the output end of coupling shaft (10) with locking pliers or other appropriate turning device and rotate coupling shaft, drive link and rotor to seat the rotor and the assembled vanes into stator half, creating the necessary clearance to assemble the seventh or full complement of seven vanes. Assemble the seven vanes using minimum force. SEE FIGURE 60.



Figure 64

Assemble seal ring in stator half 6. Place second stator half on a flat surface with seal ring groove up. Apply a small amount of grease to a **new** seal ring (3) and assemble it into stator half ring groove.

Rotor Set Component Assembly

- Assemble second stator half**
7. Assemble the second stator half over the two alignment studs and rotor with seal ring side up onto the first stator half aligning any timing marks applied for this purpose. SEE FIGURE 65.



Figure 65

CAUTION

CAUTION: If the stator half is a different height (thickness) than stator half the stator vanes or of the same length (height) as the stator half must be reassembled in their respective stator half for the rotor set to function properly.

- Assemble vanes**
8. Assemble six vanes, or as many vanes that will readily assemble into the stator vane pockets. SEE FIGURE 66.



Figure 66

- Assemble full complement of vanes**
9. Grasp the output end of coupling shaft (10) with locking pliers or other appropriate turning device and rotate coupling shaft, drive link and rotor to seat the rotor and the assembled vanes into stator, creating the necessary clearance to assemble the seventh or full complement of seven vanes. Assemble the seven vanes using minimum force. SEE FIGURE 60.

Go to Torqmotor™ assembly procedure #13, to continue Torqmotor™ assembly.



Figure 67

Final Checks

Final Checks

- Pressurize the Torqmotor™ with 100 p.s.i. dry air or nitrogen and submerge in solvent to check for external leaks.
- Check Torqmotor™ for rotation. Torque required to rotate coupling shaft should not be more than 50 ft. lbs. (68 N m)
- Pressure port with “A” cast under it on housing (17) is for clockwise coupling shaft rotation as viewed from the output end of coupling shaft. Pressure port with “B” cast under it is for counter clockwise coupling shaft rotation.
- Use test stand if available, to check operation of the Torqmotor™.

Hydraulic Fluid

Keep the hydraulic system filled with one of the following:

- 10W40 SE or SF manufacturers suggested oil.
- Hydraulic fluid as recommended by equipment manufacturer, but the viscosity should not drop below 50 SSU or contain less than .125% zinc anti-wear additives.

CAUTION: Do not mix oil types. Any mixture, or an unapproved oil, could deteriorate the seals. Maintain the proper fluid level in the reservoir. When changing fluid, completely drain old oil from the system. It is suggested also that you flush the system with clean oil.

Filtration

Recommended filtration 40-50 micron.

Oil Temperature

Maximum operating temperature 200°F (93.3° C).

Tips**Tips for Maintaining the Torqmotor™ Hydraulic System**

- Adjust fluid level in reservoir as necessary.
- Encourage all operators to report any malfunction or accident that may have damaged the hydraulic system or component.
- Do not attempt to weld any broken Torqmotor™ component. Replace the component with original equipment only.
- Do not cold straighten, hot straighten, or bend any Torqmotor™ part.
- Prevent dirt or other foreign matter from entering the hydraulic system. Clean the area around and the filler caps before checking oil level.
- Investigate and correct any external leak in the hydraulic system, no matter how minor the leak.
- Comply with manufacturer's specifications for cleaning or replacing the filter.

CAUTION: Do not weld, braze, solder or any way alter any Torqmotor™ component.

CAUTION: Maximum operating pressure must not exceed recommended Torqmotor™ pressure capacity.

CAUTION: Always carefully inspect any system component that may have been struck or damaged during operation or in an accident. Replace any component that is damaged or that is questionable.

CAUTION: Do not force any coupling onto the Torqmotor™ coupling shaft as this could damage the unit internally.

Parker extends close technical cooperation and assistance. If problems occur which you cannot solve, please contact your local Parker approved Distributor or Parker Technical Support. Our phone number and fax number and address are on the back cover of this manual.

PARKER-HANNIFIN CORPORATION
OFFER OF SALE

1. Definitions. As used herein, the following terms have the meanings indicated.

"Buyer" means any customer receiving a Quote for Products.

"Buyer's Property" means any tools, patterns, plans, drawings, designs, specifications materials, equipment, or information furnished by Buyer, or which are or become Buyer's property.

"Confidential Information" means any technical, commercial, or other proprietary information of Seller, including, without limitation, pricing, technical drawings or prints and/or part lists, which has been or will be disclosed, delivered, or made available, whether directly or indirectly, to Buyer.

"Goods" means any tangible part, system or component to be supplied by Seller.

"Intellectual Property Rights" means any patents, trademarks, copyrights, trade dress, trade secrets or similar rights.

"Products" means the Goods, Services and/or Software as described in a Quote.

"Quote" means the offer or proposal made by Seller to Buyer for the supply of Products.

"Seller" means Parker-Hannifin Corporation, including all divisions, subsidiaries and businesses selling Products under these Terms.

"Seller's IP" means patents, trademarks, copyrights, or other intellectual property rights relating to the Products, including without limitation, names, designs, images, drawings, models, software, templates, information, any improvements or creations or other intellectual property developed prior to or during the relationship contemplated herein.

"Services" means any services to be provided by Seller.

"Software" means any software related to the Goods, whether embedded or separately downloaded.

"Special Tooling" means equipment acquired by Seller or otherwise owned by Seller necessary to manufacture Goods, including but not limited to tools, jigs, and fixtures.

"Terms" means the terms and conditions of this Offer of Sale.

2. Terms. All sales of Products by Seller will be governed by, and are expressly conditioned upon Buyer's assent to, these Terms. These Terms are incorporated into any Quote provided by Seller to Buyer. Buyer's order for any Products whether communicated to Seller verbally, in writing, by electronic data interface or other electronic commerce, shall constitute acceptance of these Terms. Seller objects to any contrary or additional terms or conditions of Buyer. Reference in Seller's order acknowledgement to Buyer's purchase order or purchase order number shall in no way constitute an acceptance of any of Buyer's terms or conditions of purchase. Any Quote made by Seller to Buyer shall be considered a firm and definite offer and shall not be deemed to be otherwise despite any language on the face of the Quote. Seller reserves all rights to accept or reject any purported acceptance by Buyer to Seller's Quote if such purported acceptance attempts to vary the terms of the Quote. If Seller ships Products after Buyer issues an acceptance to the Quote, any additional or different terms proposed by Buyer will not become part of the parties' business relationship unless agreed to in a writing that is signed by an authorized representative of Seller, excluding email correspondence. If the transaction proceeds without such agreement on the part of Seller, the business relationship will be governed solely by these Terms and the specific terms in Seller's Quote.

3. Price; Payment. The Products set forth in the Quote are offered for sale at the prices indicated in the Quote. Unless otherwise specifically stated in the Quote, prices are valid for thirty (30) days and do not include any sales, use, or other taxes or duties. Seller reserves the right to modify prices for any reason and at any time by giving ten (10) days prior written notice. Unless otherwise specified by Seller, all prices are F.C.A. Seller's facility (INCOTERMS 2020). All sales are contingent upon credit approval and full payment for all purchases is due thirty (30) days from the date of invoice (or such date as may be specified in the Quote). Under any circumstances, Buyer may not withhold or suspend payment of any amounts due and payable as a deduction, set-off or recoupment of any amount, claim or dispute with Seller. Unpaid invoices beyond the specified payment date incur interest at the rate of 1.5% per month or the maximum allowable rate under applicable law. Seller reserves the right to require advance payment or provision of securities for first and subsequent deliveries if there is any doubt, in Seller's sole determination, regarding the Buyer's creditworthiness or for other business reasons. If the requested advance payment or securities are not provided to Seller's satisfaction, Seller reserves the right to suspend performance or reject the purchase order, in whole or in part, without prejudice to Seller's other rights or remedies, including the right to full compensation. Seller may revoke or shorten any payment periods previously granted in Seller's sole determination. The rights and remedies herein reserved to Seller are cumulative and in

addition to any other or further rights and remedies available at law or in equity. No waiver by Seller of any breach by Buyer of any provision of these terms will constitute a waiver by Seller of any other breach of such provision.

4. Shipment; Delivery; Title and Risk of Loss. All delivery dates are approximate, and Seller is not responsible for damages or additional costs resulting from any delay. All deliveries are subject to our ability to procure materials from our suppliers. Regardless of the manner of shipment, delivery occurs and title and risk of loss or damage pass to Buyer, upon placement of the Products with the carrier at Seller's facility. Unless otherwise agreed prior to shipment and for domestic delivery locations only, Seller will select and arrange, at Buyer's sole expense, the carrier and means of delivery. When Seller selects and arranges the carrier and means of delivery, freight and insurance costs for shipment to the designated delivery location will be prepaid by Seller and added as a separate line item to the invoice. Buyer shall be responsible for any additional shipping charges incurred by Seller due to Buyer's acts or omissions. Buyer shall not return or repackage any Products without the prior written authorization from Seller, and any return shall be at the sole cost and expense of Buyer.

5. Warranty. The warranty for the Products is as follows:

(i) Goods are warranted against defects in material or workmanship for a period of twelve (12) months from the date of delivery or 2,000 hours of use, whichever occurs first; (ii) Services shall be performed in accordance with generally accepted practices and using the degree of care and skill that is ordinarily exercised and customary in the field to which the Services pertain and are warranted for a period of six (6) months from the date of completion of the Services; and (iii) Software is only warranted to perform in accordance with applicable specifications provided by Seller to Buyer for ninety (90) days from the date of delivery or, when downloaded by a Buyer or end-user, from the date of the initial download. All prices are based upon the exclusive limited warranty stated above, and upon the following disclaimer: **EXEMPTION CLAUSE; DISCLAIMER OF WARRANTY, CONDITIONS, REPRESENTATIONS: THIS WARRANTY IS THE SOLE AND ENTIRE WARRANTY, CONDITION, AND REPRESENTATION, PERTAINING TO PRODUCTS. SELLER DISCLAIMS ALL OTHER WARRANTIES, CONDITIONS, AND REPRESENTATIONS, WHETHER STATUTORY, EXPRESS OR IMPLIED, INCLUDING BUT NOT LIMITED TO THOSE RELATING TO DESIGN, NONINFRINGEMENT, MERCHANTABILITY, AND FITNESS FOR A PARTICULAR PURPOSE. SELLER DOES NOT WARRANT THAT THE SOFTWARE IS ERROR-FREE OR FAULT-TOLERANT, OR THAT BUYER'S USE THEREOF WILL BE SECURE OR UNINTERRUPTED, UNLESS OTHERWISE AUTHORIZED IN WRITING BY SELLER, THE SOFTWARE SHALL NOT BE USED IN CONNECTION WITH HAZARDOUS OR HIGH-RISK ACTIVITIES OR ENVIRONMENTS. EXCEPT AS EXPRESSLY STATED HEREIN, ALL PRODUCTS ARE PROVIDED "AS IS"**.

6. Claims; Commencement of Actions. Buyer shall promptly inspect all Products upon receipt. No claims for shortages will be allowed unless reported to Seller within ten (10) days of delivery. Buyer shall notify Seller of any alleged breach of warranty within thirty (30) days after the date the non-conformance is or should have been discovered by Buyer. Any claim or action against Seller based upon breach of contract or any other theory, including tort, negligence, or otherwise must be commenced within twelve (12) months from the date of the alleged breach or other alleged event, without regard to the date of discovery.

7. LIMITATION OF LIABILITY. IN THE EVENT OF A BREACH OF WARRANTY, SELLER WILL, AT ITS OPTION, REPAIR OR REPLACE THE NON-CONFORMING PRODUCTS, RE-PERFORM THE SERVICES, OR REFUND THE PURCHASE PRICE PAID WITHIN A REASONABLE PERIOD OF TIME. IN NO EVENT IS SELLER LIABLE FOR ANY SPECIAL, INDIRECT, INCIDENTAL OR CONSEQUENTIAL DAMAGES INCLUDING ANY LOSS OF REVENUE OR PROFITS, WHETHER BASED IN CONTRACT, TORT OR OTHER LEGAL THEORY. IN NO EVENT SHALL SELLER'S LIABILITY UNDER ANY CLAIM MADE BY BUYER EXCEED THE PURCHASE PRICE PAID FOR THE PRODUCTS.

8. Confidential Information. Buyer acknowledges and agrees that Confidential Information has been and will be received in confidence and will remain the property of Seller. Buyer further agrees that it will not use Seller's Confidential Information for any purpose other than for the benefit of Seller and shall return all such Confidential Information to Seller within thirty (30) days upon request.

9. Loss to Buyer's Property. Buyer's Property will be considered obsolete and may be destroyed by Seller after two (2) consecutive years have elapsed without Buyer ordering the Products manufactured using Buyer's Property.

Also, Seller shall not be responsible for any loss or damage to Buyer's Property while it is in Seller's possession or control.

10. Special Tooling. Seller may impose a tooling charge for any Special Tooling. Special Tooling shall be and remain Seller's property. In no event will Buyer acquire any interest in the Special Tooling, even if such Special Tooling has been specially converted or adapted for manufacture of Goods for Buyer and notwithstanding any charges paid by Buyer. Unless otherwise agreed, Seller has the right to alter, discard or otherwise dispose of any Special Tooling or other property owned by Seller in its sole determination at any time.

11. Security Interest. To secure payment of all sums due from Buyer, Seller retains a security interest in all Products delivered to Buyer and, Buyer's acceptance of these Terms is deemed to be a Security Agreement under the Uniform Commercial Code. Buyer authorizes Seller as its attorney to execute and file on Buyer's behalf all documents Seller deems necessary to perfect Seller's security interest.

12. User Responsibility. Buyer, through its own analysis and testing, is solely responsible for making the final selection of the Products and assuring that all performance, endurance, maintenance, safety and warning requirements of the application of the Products are met. Buyer must analyze all aspects of the application and follow applicable industry standards, specifications, and any technical information provided with the Quote or the Products, such as Seller's instructions, guides and specifications. If Seller provides options of or for Products based upon data or specifications provided by Buyer, Buyer is responsible for determining that such data and specifications are suitable and sufficient for all applications and reasonably foreseeable uses of the Products. In the event Buyer is not the end-user of the Products, Buyer will ensure such end-user complies with this paragraph.

13. Use of Products, Indemnity by Buyer. Buyer shall comply with all instructions, guides and specifications provided by Seller with the Quote or the Products. If Buyer uses or resells the Products in any way prohibited by Seller's instructions, guides or specifications, or Buyer otherwise fails to comply with Seller's instructions, guides and specifications, Buyer acknowledges that any such use, resale, or non-compliance is at Buyer's sole risk. Further, Buyer shall indemnify, defend, and hold Seller harmless from any losses, claims, liabilities, damages, lawsuits, judgments and costs (including attorney fees and defense costs), whether for personal injury, property damage, intellectual property infringement or any other claim, arising out of or in connection with: (a) improper selection, design, specification, application, or any misuse of Products; (b) any act or omission, negligent or otherwise, of Buyer; (c) Seller's use of Buyer's Property; (d) damage to the Products from an external cause, repair or attempted repair by anyone other than Seller, failure to follow instructions, guides and specifications provided by Seller, use with goods not provided by Seller, or opening, modifying, deconstructing, tampering with or repackaging the Products; or (e) Buyer's failure to comply with these Terms, including any legal or administrative proceedings, collection efforts, or other actions arising from or relating to such failure to comply. Seller shall not indemnify Buyer under any circumstance except as otherwise provided in these Terms.

14. Cancellations and Changes. Buyer may not cancel or modify, including but not limited to movement of delivery dates for the Products, any order for any reason except with Seller's written consent and upon terms that will indemnify, defend and hold Seller harmless against all direct, incidental and consequential loss or damage and any additional expense. Seller, at any time, may change features, specifications, designs and availability of Products.

15. Assignment. Buyer may not assign its rights or obligations without the prior written consent of Seller.

16. Force Majeure. Seller is not liable for delay or failure to perform any of its obligations by reason of any events or circumstances beyond its reasonable control. Such circumstances include without limitation: accidents, labor disputes or stoppages, government acts or orders, acts of nature, pandemics, epidemics, other widespread illness, or public health emergency, cyber related disruptions, cyber-attacks, ransomware sabotage, delays or failures in delivery from carriers or suppliers, shortages of materials, sudden increases in the price of raw material or components, shutdowns or slowdowns affecting the supply of raw materials or components, or the transportation thereof, oil shortages or oil price increases, energy crisis, energy or fuel interruption, war (whether declared or not) or the serious threat of same, riots, rebellions, acts of terrorism, embargoes, fire or any reason whether similar to the foregoing or otherwise. Seller will resume performance as soon as practicable after the event of force majeure has been removed. All delivery dates affected by an event of force majeure shall be tolled for the duration of such event of force majeure and rescheduled for mutually agreed dates as soon as practicable after the event of force majeure ceases to exist. The right to allocate capacity is in the Seller's sole discretion. An event of force majeure shall not include

financial distress, insolvency, bankruptcy, or other similar conditions affecting one of the parties, affiliates and/or subcontractors. An event of force majeure in the meaning of these Terms means any circumstances beyond Seller's control that permanently or temporarily hinders performance, even where that circumstance was already foreseen. Buyer shall not be entitled to cancel any orders following its claim of an event of force majeure.

17. Waiver and Severability. Failure to enforce any provision of these Terms will not invalidate that provision; nor will any such failure prejudice either party's right to enforce that provision in the future. Invalidation of any provision of these Terms shall not invalidate any other provision herein and, the remaining provisions will remain in full force and effect.

18. Duration. Unless otherwise stated in the Quote, any agreement governed by or arising from these Terms shall: (a) be for an initial duration of one (1) year; and (b) shall automatically renew for successive one-year terms unless terminated by Buyer with at least 180-days written notice to Seller or if Seller terminates the agreement pursuant to Section 19 of these Terms.

19. Termination. Seller may, without liability to Buyer, terminate any agreement governed by or arising from these Terms for any reason and at any time by giving Buyer thirty (30) days prior written notice. Seller may immediately terminate, in writing, if Buyer: (a) breaches any provision of these Terms, (b) becomes or is deemed insolvent, (c) appoints or has appointed a trustee, receiver or custodian for all or any part of Buyer's property, (d) files a petition for relief in bankruptcy on its own behalf, or one is filed against Buyer by a third party, (e) makes an assignment for the benefit of creditors; or (f) dissolves its business or liquidates all or a majority of its assets.

20. Ownership of Rights. Buyer agrees that (a) Seller (and/or its affiliates) owns or is the valid licensee of Seller's IP and (b) the furnishing of information, related documents or other materials by Seller to Buyer does not grant or transfer any ownership interest or license in or to Seller's IP to Buyer, unless expressly agreed in writing. Without limiting the foregoing, Seller retains ownership of all Software supplied to Buyer. In no event shall Buyer obtain any greater right in and to the Software than a right in a license limited to the use thereof and subject to compliance with any other terms provided with the Software. Buyer further agrees that it will not, directly or through intermediaries, reverse engineer, decompile, or disassemble any Software (including firmware) comprising or contained within a Product, except and only to the extent that such activity may be expressly permitted, either by applicable law or, in the case of open source software, the applicable open source license.

21. Indemnity for Infringement of Intellectual Property Rights. Seller is not liable for infringement of any Intellectual Property Rights except as provided in this Section. Seller will defend at its expense and will pay the cost of any settlement or damages awarded in an action brought against Buyer based on a third-party claim that one or more of the Products infringes the Intellectual Property Rights of a third party in the country of delivery of the Products by Seller to Buyer. Seller's obligation to defend and indemnify Buyer is contingent on Buyer notifying Seller within ten (10) days after Buyer becomes aware of any such claim, and Seller having sole control over the defense of the claim including all negotiations for settlement or compromise. If one or more Products is subject to such a claim, Seller may, at its sole expense and option, procure for Buyer the right to continue using the Products, replace or modify the Products to render them non-infringing, or offer to accept return of the Products and refund the purchase price less a reasonable allowance for depreciation. Seller has no obligation or liability for any claim of infringement: (i) arising from information provided by Buyer (including Seller's use of Buyer's Property); or (ii) directed to any Products for which the designs are specified in whole or part by Buyer; or (iii) resulting from the modification, combination or use in a system of any Products. The foregoing provisions of this Section constitute Seller's sole and exclusive liability and Buyer's sole and exclusive remedy for claims of infringement of Intellectual Property Rights.

22. Governing Law. These Terms, the terms of any Quote, and the sale and delivery of all Products are deemed to have taken place in, and shall be governed and construed in accordance with, the laws of the State of Ohio, as applicable to contracts executed and wholly performed therein and without regard to conflicts of laws principles. Buyer irrevocably agrees and consents to the exclusive jurisdiction and venue of the courts of Cuyahoga County, Ohio with respect to any dispute, controversy or claim arising out of or relating to the sale and delivery of the Products.

23. Entire Agreement. These Terms, along with the terms set forth in the Quote, forms the entire agreement between the Buyer and Seller and constitutes the final, complete and exclusive expression of the terms of sale and purchase. In the event of a conflict between any term set forth in the Quote and these Terms, the terms set forth in the Quote shall prevail. All prior or contemporaneous written or oral agreements or negotiations with

respect to the subject matter shall have no effect. No modification to these Terms will be binding on Seller unless agreed to in a writing that is signed by an authorized representative of Seller, excluding email correspondence, 'clickwrap' or other purported electronic assent to different or additional terms. Sections 2-25 of these Terms shall survive termination or cancellation of any agreement governed by or arising from these Terms.

24. No 'Wrap' Agreements/No Authority to Bind. Seller's clicking any buttons or any similar action, such as clicking "I Agree" or "Confirm," to utilize Buyer's software or webpage for the placement of orders, is NOT an agreement to Buyer's Terms and Conditions. **NO EMPLOYEE, AGENT OR REPRESENTATIVE OF SELLER HAS THE AUTHORITY TO BIND SELLER BY THE ACT OF CLICKING ANY BUTTON OR SIMILAR ACTION ON BUYER'S WEBSITE OR PORTAL.**

25. Compliance with Laws. Buyer agrees to comply with all applicable laws, regulations, and industry and professional standards, including those of the United States of America, and the country or countries in which Buyer may operate, including without limitation the U.S. Foreign Corrupt Practices Act ("FCPA"), the U.S. Anti-Kickback Act ("Anti-Kickback Act"), U.S. and E.U. export control and sanctions laws ("Export Laws"), the U.S. Food Drug and Cosmetic Act ("FDCA"), and the rules and regulations promulgated by the U.S. Food and Drug Administration ("FDA"), each as currently amended. Buyer agrees to indemnify, defend, and hold harmless Seller from the consequences of any violation of such laws, regulations and standards by Buyer, its employees or agents. Buyer represents that it is familiar with all applicable provisions of the FCPA, the Anti-Kickback Act, Export Laws, the FDCA and the FDA and certifies that Buyer will adhere to the requirements thereof and not take any action that would make Seller violate such requirements. Buyer represents and agrees that Buyer will not make any payment or give anything of value, directly or indirectly, to any governmental official, foreign political party or official thereof, candidate for foreign political office, or commercial entity or person, for any improper purpose, including the purpose of influencing such person to purchase Products or otherwise benefit the business of Seller. Buyer further represents and agrees that it will not receive, use, service, transfer or ship any Products from Seller in a manner or for a purpose that violates Export Laws or would cause Seller to be in violation of Export Laws. Buyer agrees to promptly and reliably provide Seller all requested information or documents, including end-user statements and other written assurances, concerning Buyer's ongoing compliance with Export Law.



Parker Hannifin Corporation
2745 Snapps Ferry Road
Greeneville, TN 37745 USA
Tel: (423) 639-8151
FAX: (423) 787-2418
www.parker.com/pumpmotor